

Operating Instructions

Sectional door drive with integrated control VTA

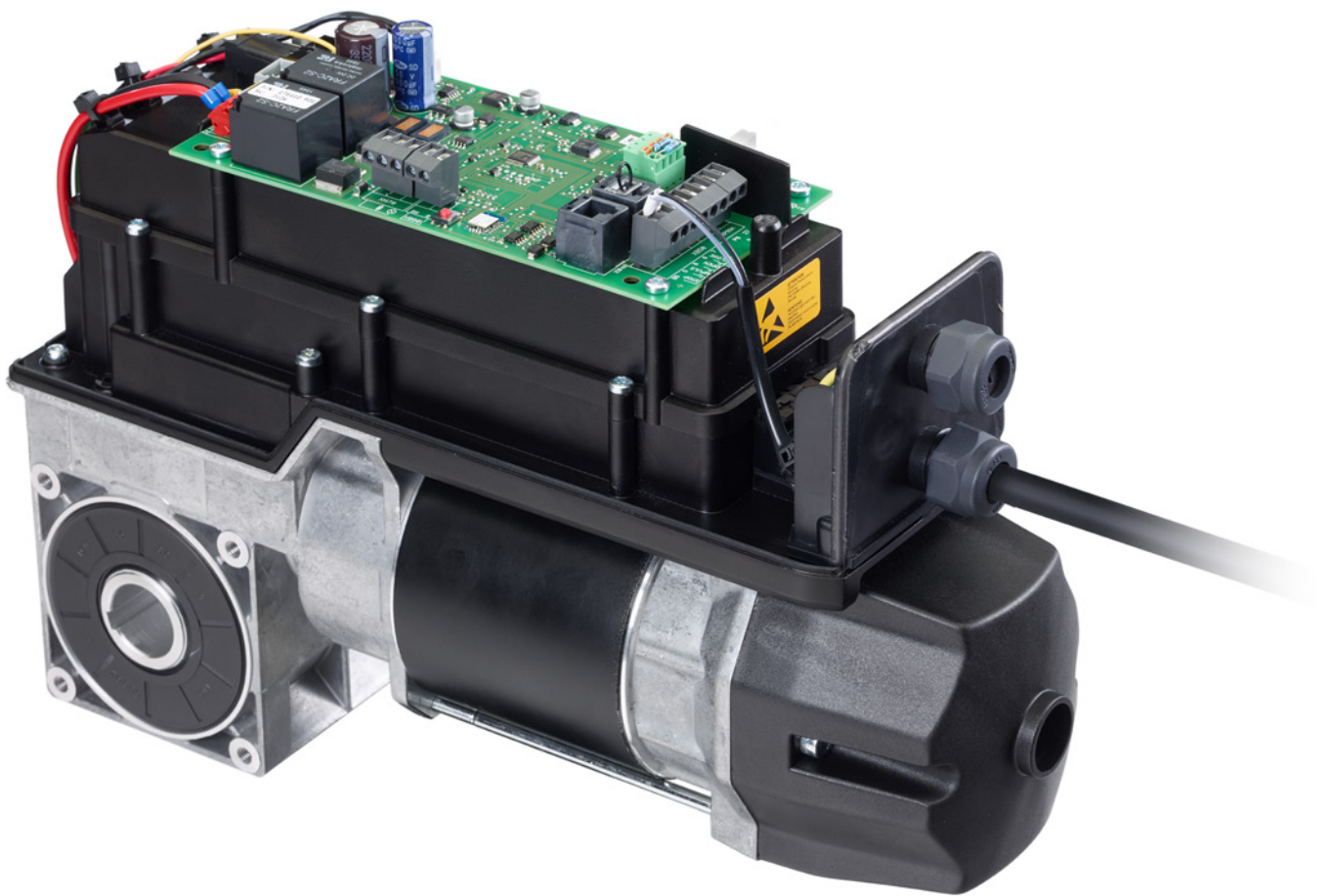

Table of contents

1.	Safety information	3
1.1	Intended use	3
1.2	Target groups	3
1.3	General safety instructions	4
2.	Product information	4
2.1	Scope of supply	4
2.2	Technical data	5
3.	Installation	7
3.1	Safety instructions for installation	7
3.2	Preparation for installation	7
3.3	Plug-in installation	7
3.4	Mounting the emergency hand chain (only with drives with an emergency hand chain)	9
3.5	Opening the control	9
3.6	Control connections	9
3.7	Connection of the mains cable	16
3.8	Pairing maveo/pro via Bluetooth, SBlE	17
3.9	Completing installation	17
4.	Start-up	18
4.1	Safety instructions for start-up	18
4.2	Overview of the control	18
4.3	Status display	19
4.4	Factory settings	19
4.5	Quick programming	19
4.6	Function test	21
4.7	Special programming	22
5.	Operation	30
5.1	Safety instructions for operation	30
5.2	Operating systems	30
5.3	Emergency operation	30
6.	Care	32
7.	Maintenance	33
8.	Disassembly	33
9.	Disposal	33
10.	Troubleshooting	34
11.	Annex	36
11.1	Manufacturer's declaration	36

About this document

- Original instructions.
- Part of the product.
- Must be read and stored.
- Copyright protected.
- Reprinting, including extracts, only with our permission.
- Subject to change due to technical advancement.
- All dimensions in millimetres.
- Illustrations are not to scale.

Safety instructions

WARNING!

Safety note indicating a danger that may result in death or serious injuries.



CAUTION!

Safety note indicating a danger that may result in minor to moderate injuries.

ATTENTION!

Safety note indicating a danger that could lead to damage or the destruction of the product.

Explanation of symbols

- Action instruction
- ✓ Check
- List, bullet points
- Reference to a separate part of this document
-  Reference to separate documents that must be observed
-  Factory setting

1. Safety information

WARNING!

Danger due to a failure to comply with the operating manual!

This manual contains important information for safe use of the product. Potential dangers are specifically highlighted.

- Read this manual through carefully.
- Follow the safety instructions in this manual.
- Store the manual in an accessible location.

1.1 Intended use

The drive system is designed exclusively for opening and closing doors. Use is only permissible:

- On weight-balanced sectional doors.
Fall protection is essential in case of gear units with unlocking.
 - In dry rooms.
 - In a technically faultless condition.
 - After correct installation.
 - In accordance with the specifications in the technical data.
- "2.2 Technical data"

Any other use is deemed to be misuse.

1.2 Target groups

1.2.1 Operator

The operator is responsible for the building in which the product is used. The operator has the following tasks:

- Knowledge and storage of the operating manual.
- Instruction of persons who use the door system.
- Ensuring that the door system is tested and maintained regularly by qualified specialist personnel in accordance with the manufacturer's instructions.
- Ensuring that testing and maintenance are documented in the log book.
- Storage of the log book.

1.2.2 Specialist personnel

Qualified specialist personnel are responsible for installation, start-up, maintenance, repair, disassembly and disposal.

Requirements applicable to qualified specialist personnel:

- Knowledge of the general and specific safety and accident prevention regulations.
- Knowledge of the relevant electrical regulations.
- Training in the use and care of appropriate safety equipment.
- Knowledge of application of the following standards
 - EN 12635 ("Doors - Installation and use"),
 - EN 12453 ("Doors - Safety in use of power operated doors – Requirements"),
 - EN 12445 ("Doors - Safety in use of power operated doors – Test methods"),
 - EN 13241-1 ("Doors - Product standard - Part 1: Products without fire resistance or smoke control characteristics").

Electrical work must be performed by qualified electricians in accordance with DIN VDE 0100.

Requirements applicable to qualified electricians:

- Knowledge of the basics of electrical engineering.
- Knowledge of the country-specific provisions and standards.
- Knowledge of the relevant safety provisions.
- Knowledge of this operating manual.

1.2.3 Users

Instructed users operate and maintain the product.

Requirements applicable to instructed users:

- Users have been instructed on their work by the operator.
- Users have been instructed on safe use of the product.
- Knowledge of this operating manual.

Special requirements apply to the following users:

- Children aged 8 years and over.
- Persons with limited physical, sensory or mental capabilities.
- Persons with a lack of experience and expertise.

These users may only be involved in the operation of the product.

Special requirements:

- Users are supervised.
- Users have been instructed on safe use of the product.
- Users understand the dangers when handling the product.
- Children are not permitted to play with the product.

1.3 General safety instructions

Persons or objects must never be moved with the help of the door.

In the following cases, the manufacturer accepts no liability for damages. The guarantee provided on the product and accessory parts is voided with:

- A failure to observe this operating manual.
- Misuse and incorrect handling.
- Use of unqualified personnel.
- Modifications or changes to the product.
- Use of spare parts that have not been produced or approved by the manufacturer.

The product is manufactured in accordance with directives and standards listed in the declaration of incorporation. The product left the factory in a technically safe and faultless condition.

Excluded from the warranty are batteries, rechargeable batteries, fuses and bulbs.

Further safety instructions can be found in the respective relevant sections of the document.

- "3.1 Safety instructions for installation"
- "4.1 Safety instructions for start-up"
- "5.1 Safety instructions for operation"

2. Product information

2.1 Scope of supply





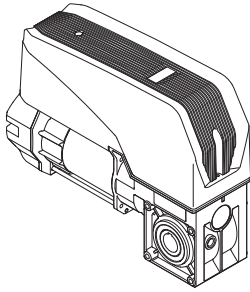
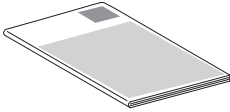

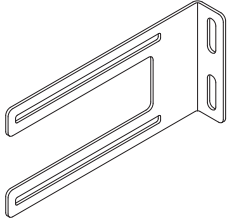

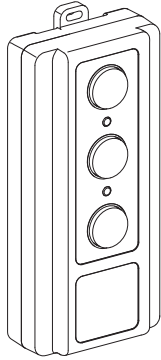
- Refer to the table to check the scope of supply for your product variant.

Country-specific deviations are possible.

Pos.	Drive	
1		1x
2		1x

Pos.	Torque support	
3		1x

Pos.	3-fold button CS-I 15	
4		1x

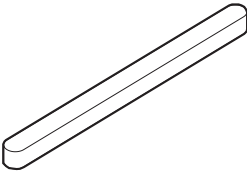
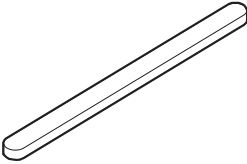
Pos.	VTA accessories bag	
5		2x
6		2x
7		2x
8		2x
9		4x
10		4x
11		4x
12		4x
13		1x
14		1x

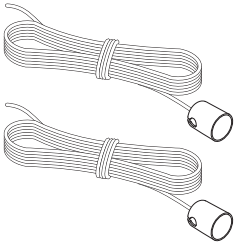
Pos.	Quick unlocking	
15		1x

 You can find further information on the accessory items on the manufacturer's website. Observe the corresponding instructions for the installation and wiring of door sensors, control and safety elements.

2.2 Technical data

Application area Standard sectional doors with cylindrical rope drum

VTA 14-61

Door area (max.)	m ²	18
Door weight (max.)	kg	234
maximum cable drum-Ø	mm	< 160

Application area Vertically guided sectional doors with conical rope drum

VTA 14-61

Door area (max.)	m ²	10
Door weight (max.)	kg	130
maximum cable drum-Ø	mm	< 220

Application area Height-guided sectional doors with cylindrical-conical cable drum

VTA 14-61

Door area (max.)	m ²	18
Door weight (max.)	kg	234
maximum cable drum-Ø	mm	< 160 mm cylindrical, < 200 mm conical

Mechanical data

VTA 14-61

Output torque	Nm	25
Static holding moment	Nm	400
Output speed (nominal speed)	min ⁻¹	24
Output shaft revolutions		13
Hollow shaft	mm	25.4
Emergency operation		E (Unlocking) KE (Chain) KU (Crank)

Electrical data

VTA 14-61

Nominal voltage, country-specific deviations possible	V	85 – 365
Mains frequency	Hz	50/60
Current draw	A	1.1 - 2.5
Power	KW	0.15 - 0.3
max. cycles per hour		20*
Protection class		I
Protection grade	IP	54
Control voltage	V DC	24
External element supply	mA	50
customer-provided fuse (mains operation)	A	16

* With a break time of approx. 90 seconds between the cycles.

Ambient data

Unit weight (E KU KE)	kg	8 8 9
Dimensions (E KU KE)	HxWxL (mm)	90x105x320 370 370
Sound pressure level	dB(A)	< 70
Temperature range	°C	-20
	°C	+60

Temperature diagram

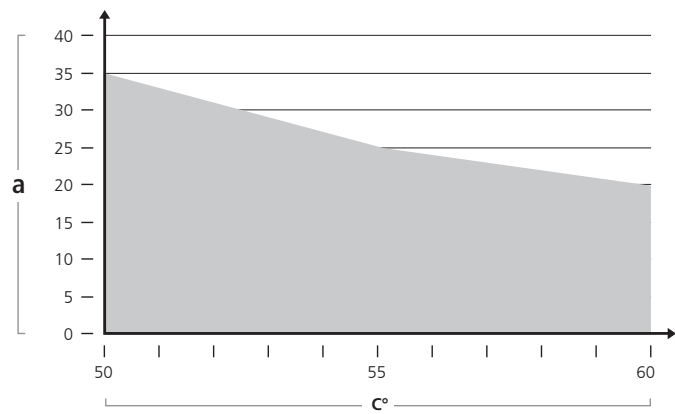

a max. cycles / hour

2.2 / 1

VTA

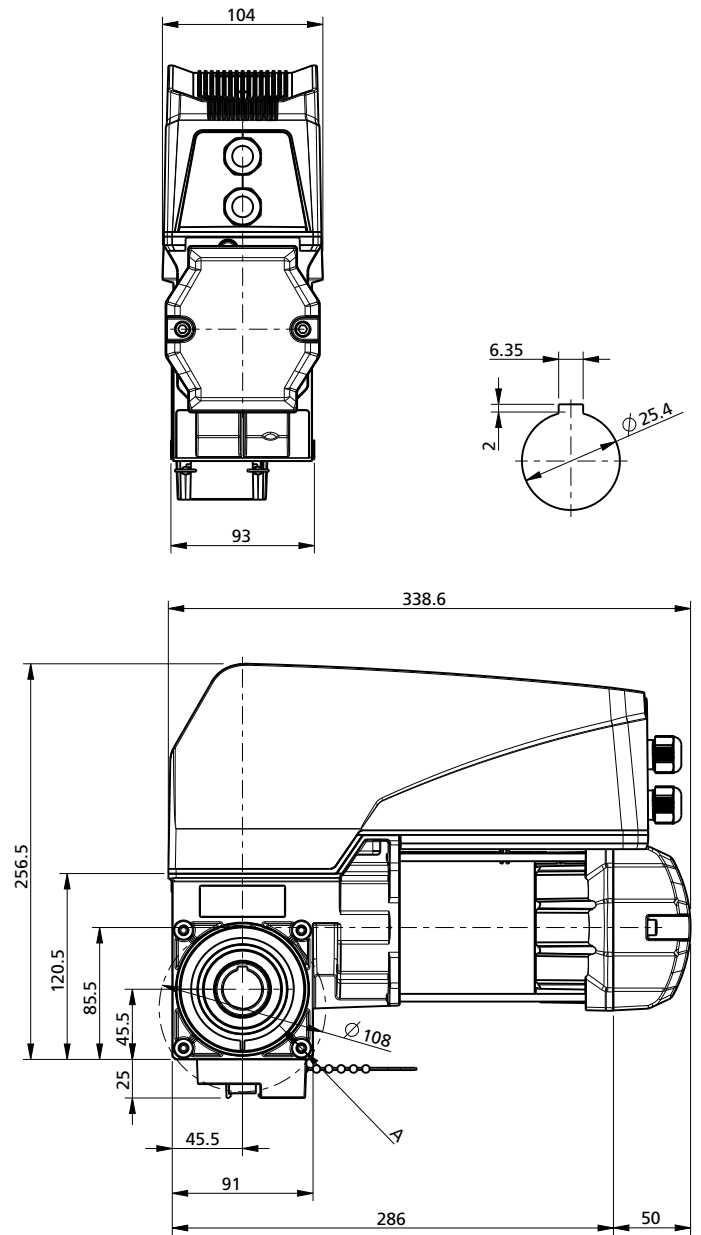

A 4x M6x12, both sides

3. Installation

3.1 Safety instructions for installation

WARNING!

Danger due to a failure to comply with the installation instructions!

This chapter contains important information for safe installation of the product.

- Read this manual through carefully before installation.
- Follow the safety instructions.
- Perform installation as described.

Installation by qualified specialist personnel only.

→ "1.2.2 Specialist personnel"

Electrical work must be performed by qualified electricians exclusively.

→ "1.2.2 Specialist personnel"

- The drive must be undamaged.
- The ambient temperature is -20 °C to +60 °C.
- The installation altitude does not exceed 1,000 above sea level.
- The correct protection type is selected.
- The drive is not jammed.
- The drive has been newly prepared after an extended time in storage.
- All connections have been established correctly.
- The direction of rotation of the gear motor is correct.
- All motor protection devices are active.
- No other danger sources are present.
- The installation location is widely cordoned off.
- The drive must be mounted free of stress.
- The drive must not be able to slide on the shaft.
- The structure and base of all components must be designed for the load.
- Installation must take place whilst standing on a stable foundation (e.g. scaffolding)
- The drive system must be secured against falling until it is fastened in place.
- Prior to wiring work, always disconnect the drive system from the power supply.
- The power supply must remain disconnected for the duration of the wiring work.
- It is essential to observe the local protective regulations.
- Mains cables and control cables must be routed separately.
The control voltage is 24 V DC.
- Install all pulse generators and control devices (e. g. radio code modulator) within sight of the door, and at a safe distance from moving parts of the door.
It is essential to observe a minimum installation height of 1.5 metres.
- Only use fastening materials that are suitable for the respective construction substrate.
- The following installation instructions must be observed

3.2 Preparation for installation

Before starting installation it is essential to perform the following work.

Scope of supply

- Check that the scope of supply is complete.
- Check whether the accessory parts required for your installation situation are available.

Door system

- Make sure that a suitable power supply and mains disconnection device are available for your door system.
The minimum cross-section of the cable is 3 x 1.5 mm².

 When using and installing accessories, observe the respective associated documentation.

3.3 Plug-in installation

ATTENTION!

Risk of property damage due to improper installation!

Installation without vibration damping can lead to damage.

- Make sure the drive is mounted on a bracket or with a torque support for vibration damping.

 When installing the drive on the door, observe the corresponding door manual.

3.3.1 Full shaft

3.3.1 / 1

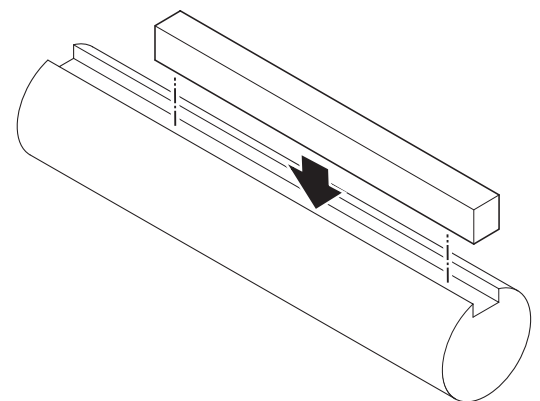

- Check that the feather key matches with the local spring shaft.

3.3.2 Installation with torque support

! WARNING!

Risk of injury due to incorrect handling!

The size and weight of the product require extensive force during installation. If the product falls, this may cause serious injuries.

- Secure the drive system against falling prior to installation.
- Observe all applicable occupational safety provisions.

Screws and wall plugs for wall mounting are not included in the scope of supply.

3.3.2 / 1

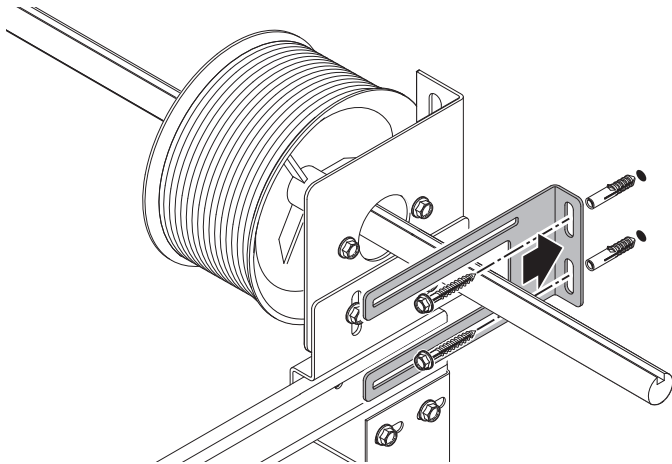

- Mount the torque support/bracket.

3.3.2 / 2

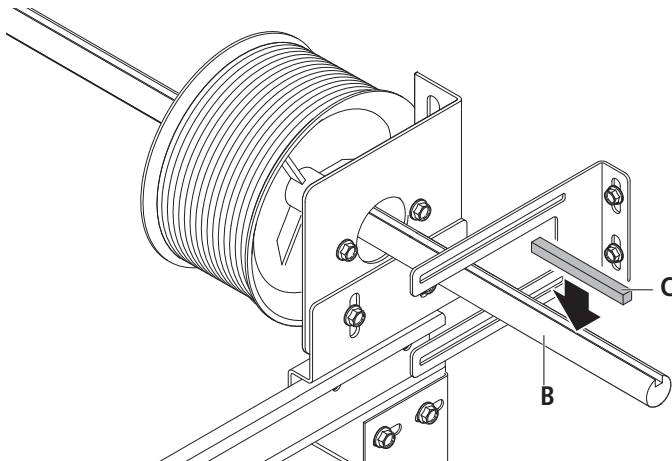

- Grease the spring shaft (B) in the area of the drive seat.
- Insert the feather key (C) in the spring shaft (B).

3.3.2 / 3

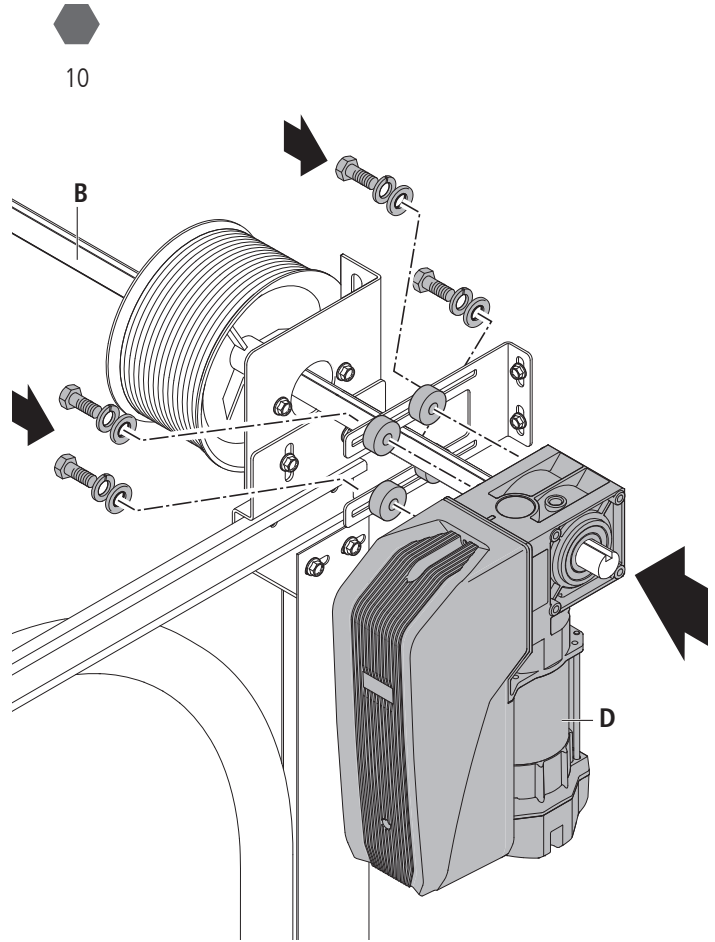

- Fit the drive (D) onto the spring shaft (B).
- Fasten the drive to the torque support with 4 screws.

3.3.2 / 4

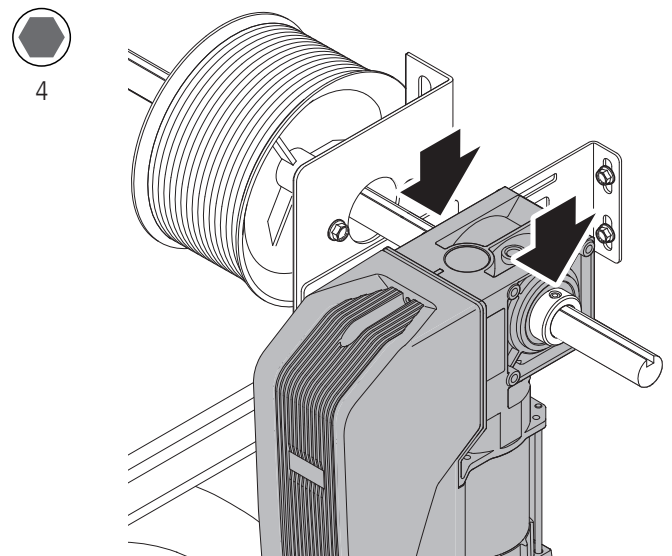

- Secure the feather key against shifting.

The feather key must be secured with two adjusting rings.

3.4 Mounting the emergency hand chain (only with drives with an emergency hand chain)

To ensure faultless functionality, the chain links must not be twisted.

3.4 / 1

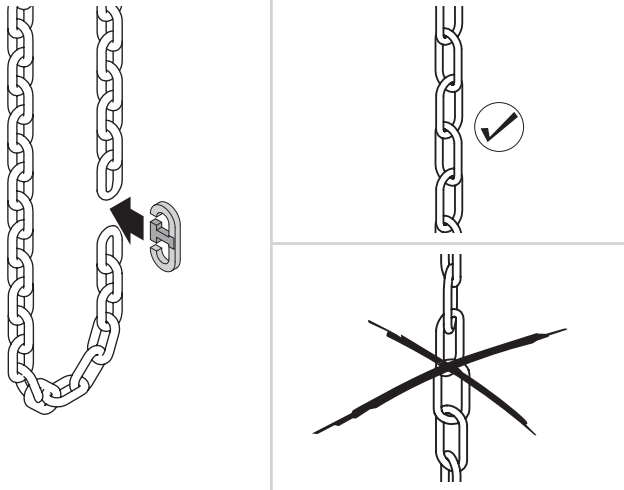

- Connect the chain ends with the chain lock.

ATTENTION!

Property damage due to improper operation of the drive!

To avoid damage to the drive and door, the emergency hand chain must be secured during electrical door operation.

3.5 Opening the control

3.5 / 1

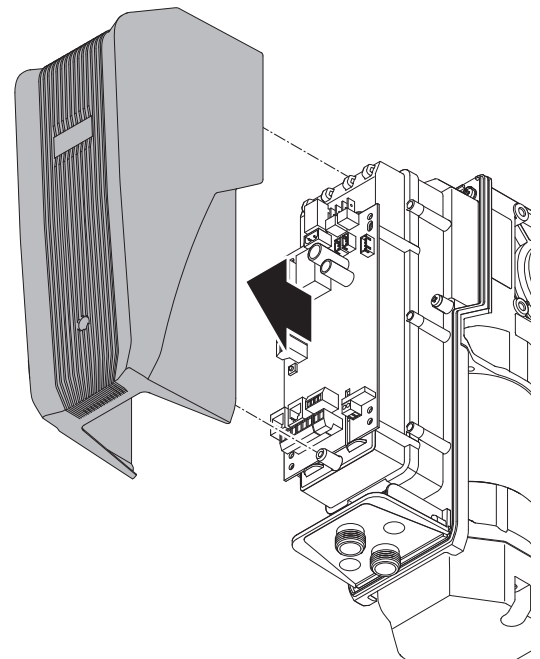

- Undo both screws on the drive hood.
- Take the hood off the drive.

3.6 Control connections

WARNING!

Risk of injury due to electric shock!

There is a danger of electric shock in case of contact with the mains voltage.

- Prior to wiring work, always disconnect the drive system from the power supply.
- Take measures to ensure that the power supply remains disconnected for the duration of the wiring work.

ATTENTION!

Risk of property damage due to improper installation!

External voltage at the connection XB50 leads to destruction of the entire electronics.

- Only connect the terminals B5, 5, 8, 6, 7 of XB50 to potential-free NO contacts.

3.6.1 Overview of the control connections

3.6.1 / 1

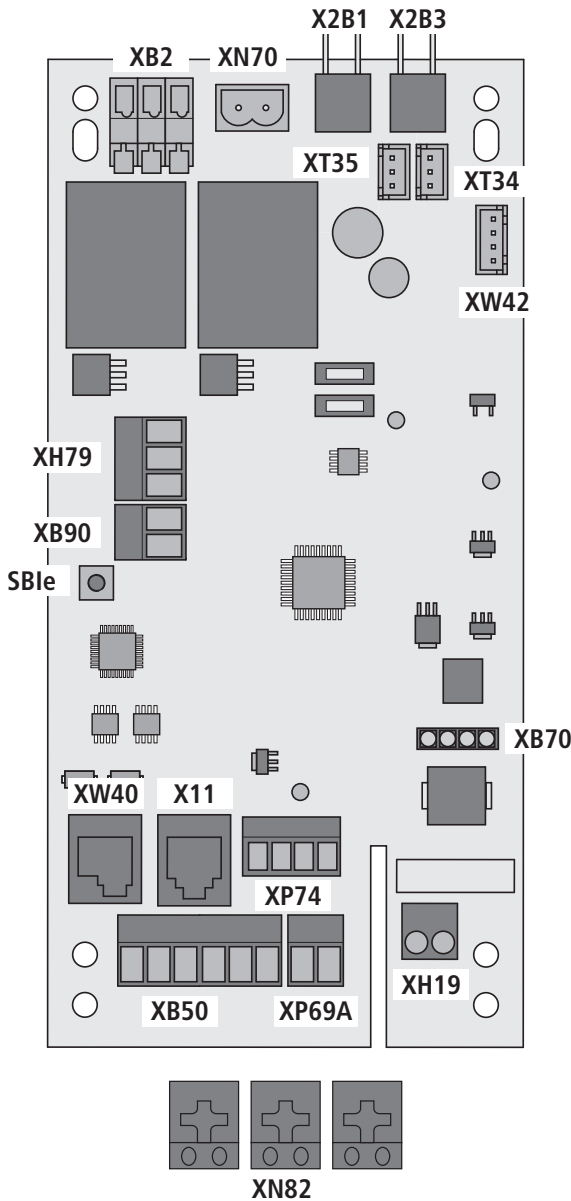

XH19	Connection external lighting / signal light, potential-free
XH79	Connection electric lock and signal light → "3.6.3 Connection XH79/XB90"
XN70	Connection battery backup
XN82	Mains input → "3.6.7 Connection XN82"
XP74	Connection closing edge protective device and 8k2 hold circuit, door
XP69A	Connection light barrier, running direction CLOSE → "3.6.5 Connection XP69A"
XT34	Connection switching mains supply 2, control cable / jumper
XT35	Connection switching mains supply 1, control cable
XW40	Connection MS-BUS
XW42	Connection position sensor

A 2-wire light barrier connected to XB69A is automatically detected by the control after "Mains on". The light barrier can be retrospectively deactivated (level 8 / menu 1).

If the contacts of a closure preventer are closed, the door system can no longer be closed.

3.6.2 Connection XB50

Delivery from the factory

B5 and 5 bridged

3.6.2 / 1

M18E004

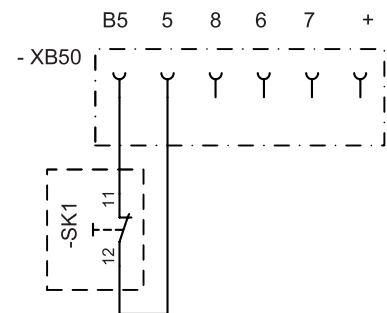

5	Connection potential-free NC contact
B5	GND
SK1	Optional safety switch NHK / KU

Additional external controls and safety equipment 24 V connection (max. 50 mA) must be connected to XB50 (B5 and +).

SBle	Button for Bluetooth connection
X2B1	Connection switching mains supply 1, power supply
X2B3	Connection switching mains supply 2, power supply
X11	Connection external controls with system wiring
XB2	Motor connection
XB50	Connection external controls → "3.6.2 Connection XB50"
XB70	Module antenna connection
XB90	Connection external pulse button

Connection option 1

3.6.2 / 2

M18E004

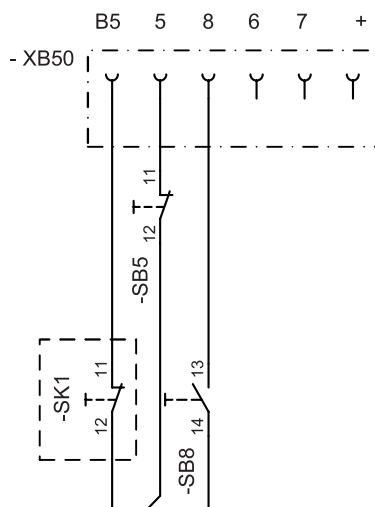

5	Connection potential-free NC contact
8	Connection potential-free NO contact
B5	GND
SB5	STOP button
SB8	PULSE button
SK1	Optional safety switch NHK / KU

Connection option 2

3.6.2 / 3

M18E004

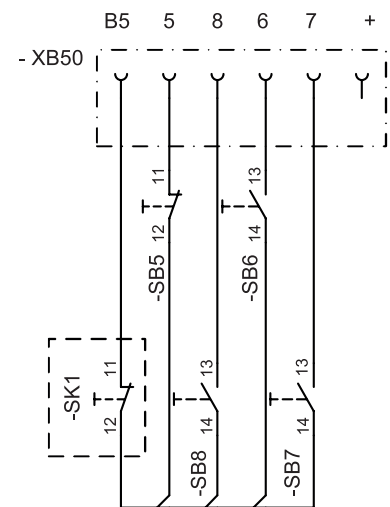

5	Connection potential-free NC contact
6	Connection potential-free NO contact
7	Connection potential-free NO contact
8	Connection potential-free NO contact
B5	GND
SB6	OPEN button
SB7	CLOSE button
SB5	STOP button
SB8	PULSE button
SK1	Optional safety switch NHK / KU

Connection option 3

3.6.2 / 4

M18E004

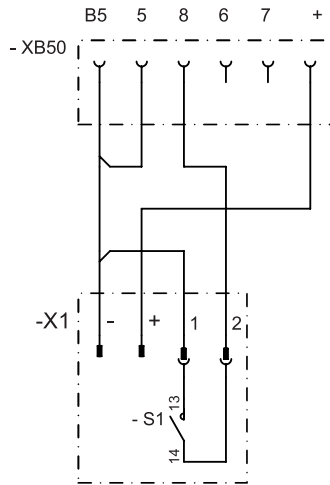

+	Connection + 24 V DC (50 mA max.)
5	Connection potential-free NC contact
8	Connection potential-free NO contact
B5	GND
S1	Receiver potential-free NO contact
X1	Connection external receiver

3.6.3 Connection XH79/XB90

3.6.3 / 1

M18E006

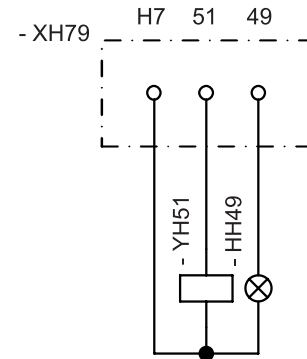

H7/49	Connection programmable output (24 V DC / 0.5 A) → "Level 1, Menu 7 - Signal light output XH79"
H7/51	Connection for electric lock 24 V DC
H7	Connection 24V DC / max. 0.7 A
HH49	Signal light 24 V DC / max. 0.7 A
YH51	Customer's electric lock

3.6.3 / 2

M18E007

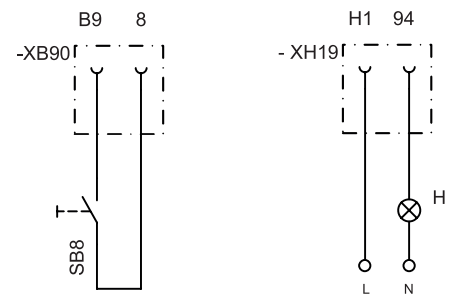

L	Phase connection
N	Neutral conductor connection
H	Signal light
SB8	Potential-free contact
XB90	Potential-free input → "Level 5, Menu 3 - Programmable input XB90"
XH19	Signal light connection, max. 60 W

Connection option

Signal light connection with external relay

3.6.3 / 3

M18E006

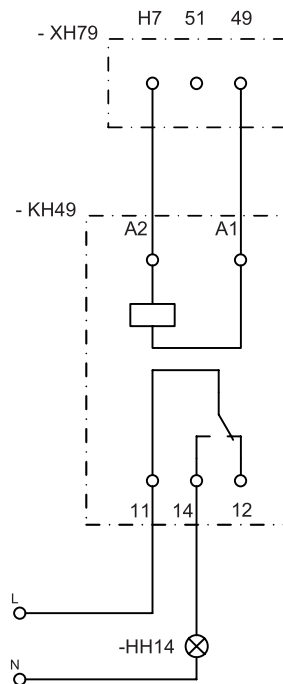

H7/49	Connection programmable output (24 V DC / 0.5 A) → "Level 1, Menu 7 - Signal light output XH79"
L	Phase connection
N	Neutral conductor connection
HH14	Signal light
KH49	Customer's relay 24 V DC

3.6.4 Connection XP74

ATTENTION!

Risk of property damage due to incorrect connection!

- When connecting a 8.2 kΩ closing edge protective device, the resistor between terminal + and 47 must be removed.
- When connecting a SP15 safety contact with integrated resistor, the resistor between terminal – and 15 must be removed.

3.6.4 / 1

M19E001d

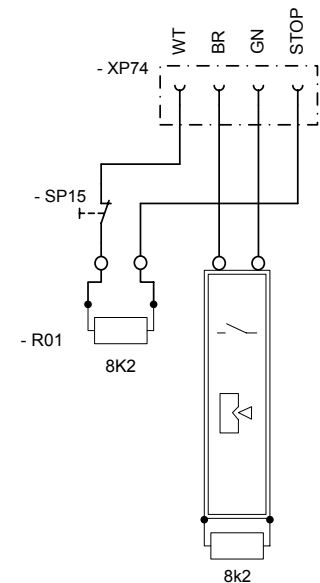

WT	GND
BR	+ (12 V)
STOP	8K2 hold circuit
GN	Signal
SP15	Safety contact, wicket door slackline protection

3.6.4 / 2

M19E001d

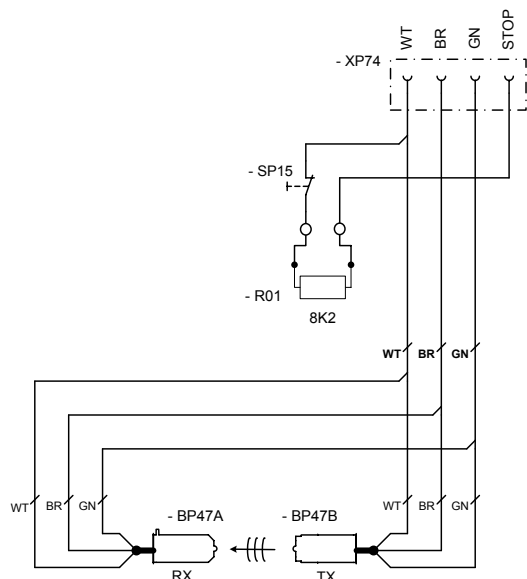

WT	GND
BR	+ (12 V)
STOP	8K2 hold circuit
GN	Signal
BP47A/B	Optical sensors
SP15	Safety contact, wicket door slackline protection

3.6.5 Connection XP69A

3.6.5 / 1

M12E017

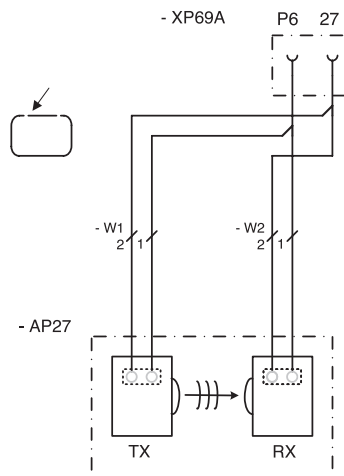

27	Light barrier signal connection Door running direction CLOSE (XP69A)
P6	Connection GND CLOSE (XP69A)
RX	Receiver of the 2-wire light barrier
TX	Transmitter of the 2-wire light barrier

A 2-wire light barrier connected to XP69A is automatically detected by the control after "Mains on".
The light barrier can be retrospectively deactivated (level 8 / menu 1).

3.6.6 External light barrier connection

3.6.6 / 1

M19E003

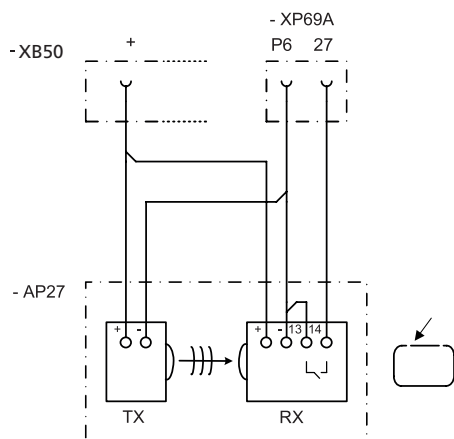

AP27	Relay light barrier
+	Power supply connection (24 V DC)
-	Power supply connection
13/14	Potential-free relay contact
RX	Light barrier receiver RX
TX	Light barrier transmitter TX
XP69A	Connection terminal light barrier 2 wire CLOSED
27	Connection light barrier CLOSED
P6	Connection GND
XB50	Connection external controls

3.6.7 Connection XN82

3.6.7 / 1

M18E005

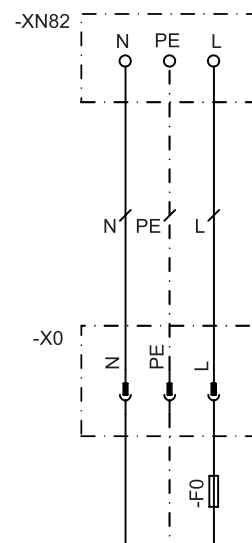

L	Phase connection
N	Neutral conductor connection
PE	Protective earth connection
FO	Customer's protective equipment
X0	Customer's mains connection, all-pole disconnectable

3.6.8 Connection external "intelligent" 3-fold button CSI-15

ATTENTION!

Risk of property damage due to incorrect connection!

Voltage peaks during installation could damage the control or the 3-fold button.

- Make sure the 3-fold button CSI-15 is plugged in whilst de-energised.
- Only use the 3-fold button from MFZOvitor (article number 120858).

3.6.8 / 1

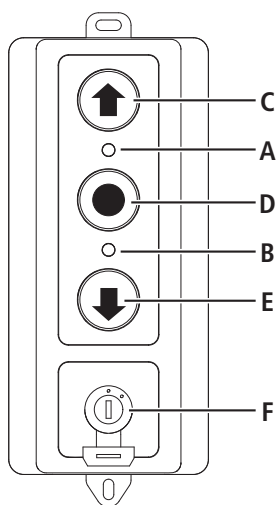

- A: LED 1 green, operating indication
- B: LED 2 red, error indication
- C: Button (▲) / (OPEN)
- D: Button (○) / (STOP)
- E: Button (▼) / (CLOSE)
- F: Key switch

3.6.8 / 2

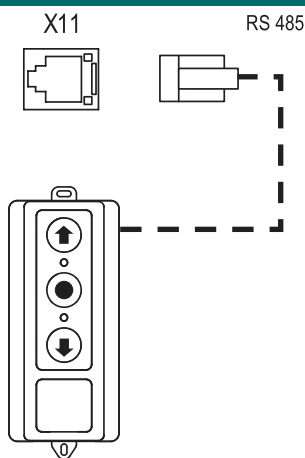

NOTE:

If no 3-fold button is connected, the connection X11 must be equipped with a bridging plug. Otherwise the controller has no function.

3.7 Connection of the mains cable

WARNING!

Risk of injury due to electric shock!

There is a danger of electric shock in case of contact with the mains voltage.

- Prior to wiring work, always disconnect the drive system from the power supply.
- Take measures to ensure that the power supply remains disconnected for the duration of the wiring work.
- Make sure an all-pole mains disconnection device is available with permanent connection of the mains cable.

3.7 / 1

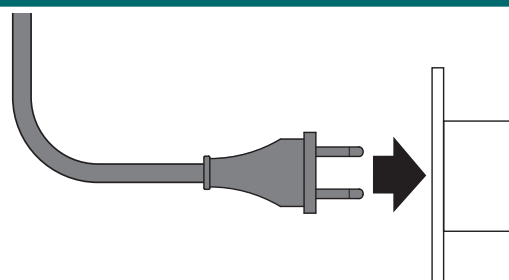

3.8 Pairing maveo/pro via Bluetooth, SBle

3.8.1 Pairing via control VTA

3.8.1 / 1

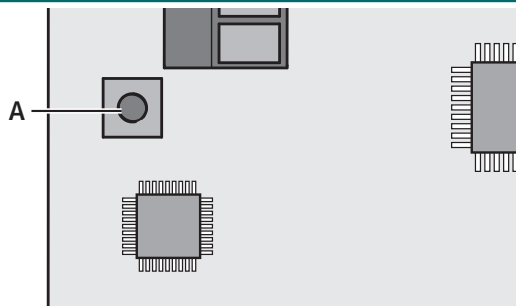

The maveo stick is integrated in the control.

In order to connect with the maveo/pro app:

- When prompted, press the button SBle (A).

After pressing the button, pairing mode will be active for 5 minutes.

Alternatively, it is possible to activate the pairing via the CSI-15.

3.8.2 Pairing via the 3-fold button CSI-15

- Press and hold the STOP (D) and CLOSE (E) button at the same time. After around 5 seconds the green LED (A) flashes, and after a further 5 seconds the green LED (A) flashes slowly.
- Release both buttons.
Pairing mode is now active.

3.9 Completing installation

Before closing the control, it is necessary to perform the following work:

→ "4. Start-up"

3.9 / 1

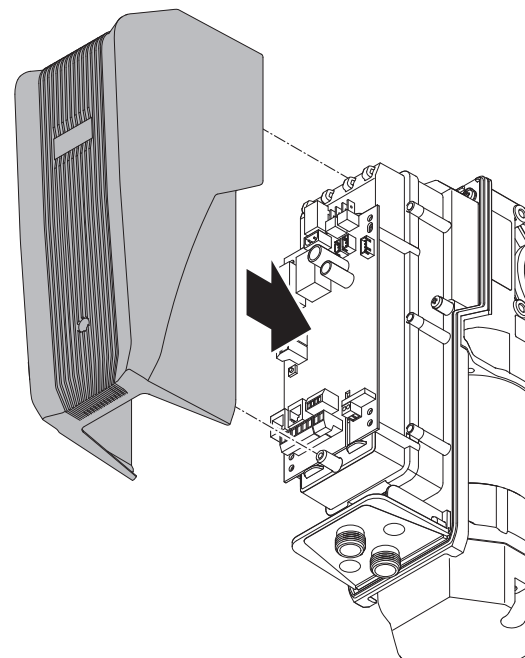

- Fit the hood on the drive.
- Fasten both screws on the drive hood.

4. Start-up

4.1 Safety instructions for start-up

! WARNING!

Danger due to a failure to comply with the start-up instructions!

This chapter contains important information for safe start-up of the product.

- Read this manual through carefully before installation.
- Follow the safety instructions.
- Perform installation as described.

Start-up by qualified specialist personnel only.

→ "1.2.2 Specialist personnel"

- Prior to wiring work, always disconnect the drive system from the power supply.
- Take measures to ensure that the power supply remains disconnected for the duration of the wiring work.

Powered windows, doors, and gates must be tested prior to first start-up and as required, although at least once annually by qualified specialist personnel with a closing force measuring device designed for this purpose (the test must be recorded in writing).

The operator of the door system or their representative must be instructed on its operation after the system has been commissioned.

- Children must not play with the door control or hand-held transmitter.
- No persons or objects are permitted inside the danger zone of the door.
- Before crossing the door opening, make sure the door is in the door OPEN position.
- It is necessary to check all available emergency command devices.
- Observe possible crushing and shearing points on the door system.
- Never reach into a running door, the guide rails or moving parts.
- Observe the provisions of EN 13241-1 ("Doors - Product standard").
- The line types and cross-sections must be selected in accordance with the valid specifications.
- The nominal currents and switching type must correspond with the information on the motor type plate.
- The drive data must concur with the connection values.

4.2 Overview of the control

An external operating unit is required for operation of the control (Command 108).

4.2 / 1

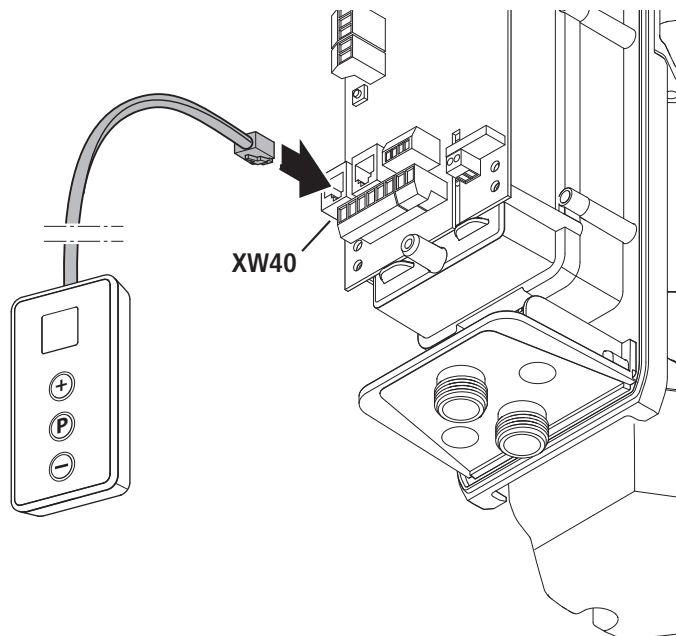

- Open the control.
→ "3.5 Opening the control"
- Connect the external operating unit.

Controls

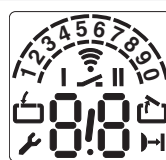

LCD display



Drive door in the OPEN direction, increase values



Drive door in the CLOSE direction, reduce values



Start programming, confirm and save values











Key



Display flashes

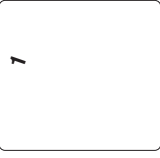

Display illuminates

Display	Function / element
	Ready for operation
	CLOSED position
	OPEN position
	Error message / maintenance display in CLOSED position
	Light barrier or closing edge protective device
	Remote control
	External button
	Status display (Example display 1 – reference point) → "4.3 Status display"
	Display of the levels (example: Level 2)
	Display of the menus and parameters (Example: Menu 3, parameter 8)
Minutes display	
	Times over one minute are displayed in minutes and seconds. Example: 1.2 = 1 minute + 20 seconds = 80 seconds

4.3 Status display

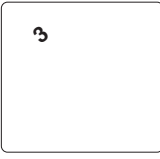
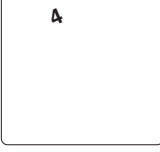
Display	Function / element
	Battery backup connected (optional)
	Display warning time (only with programmed automatic closure)

4.4 Factory settings

It is possible to reset the drive to the factory settings by means of a reset.

→ "Level 1, Menu 8 - RESET"

4.5 Quick programming

It is necessary to perform quick programming for the correct start-up of the drive system and after a reset.

Prerequisites:

- The door is currently in an intermediate position.
- The drive system is locked.

 Unlocking the drive system is described in the motor unit documentation.

If no button is pressed in programming mode within 120 seconds, the control switches back to the operating state.

A corresponding error number is displayed.

→ "10. Troubleshooting"

- Perform quick programming.
- Start with the door position OPEN.
- When programming the limit positions, make sure the limit positions are approached from a distance of at least 1,500 mm.

✓ After quick programming it is necessary to perform a function test.

→ "4.6 Function test"

If the limit positions are not precisely approached after programming:

- Correct the limit positions with the fine adjustment.
- "Level 1, Menu 9 - Limit positions - fine adjustment OPEN"
- "Level1, Menu 10 - Limit position fine adjustment CLOSE"

Quick programming

1. Programming the door position OPEN

Control is in operating mode.	
P P > 3 sec. < 10 sec.: Start of quick programming.	
+ Drive door to the OPEN position.	
P Save OPEN door position.	

2. Programming the door position CLOSED

- Drive door to the CLOSED position.	
P Save CLOSED door position.	

Quick programming

3. Programming the Multi-Bit remote control

	Actuate hand-held transmitter.	
	Release hand-held transmitter.	
P Save remote control. End of quick programming.		
Control is in operating mode.		

3. Programming the bi-linked remote control

	Actuate programming button on the hand-held transmitter.	
	Actuate hand-held transmitter.	
	Release hand-held transmitter.	
P Save remote control. End of quick programming.		
Control is in operating mode.		

4.6 Function test

4.6.1 Checking the mechanical functions









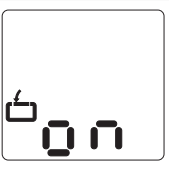

After assembling and installing all components it is necessary to check the system functions.

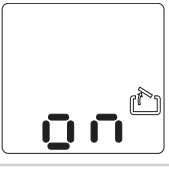
- Check the seating of the fastening screws.
- Check all system functions.
- Check that the drive runs quietly.
- Check whether the drive is losing oil.

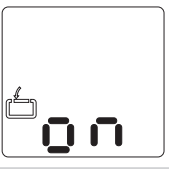
If the drive makes unusual noises or loses oil:

- Put the drive out of operation immediately.
- Inform customer service.

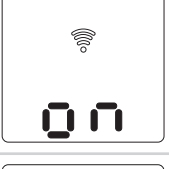
4.6.2 Checking the drive functions

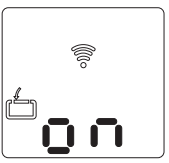
1.	Control is in operating mode.	
2.	 The door must open and drive to the saved position OPEN.	
3.	 The door must close and drive to the saved position CLOSED.	
4.	 The drive system must drive in the door OPEN or CLOSE direction.	
5.	 The drive system must stop.	
6.	 The drive system runs in the opposite direction.	

If the running direction of the door does not comply with the button commands, the direction of rotation must be changed.

The running direction must then be checked again.

→ "Level 8, Menu 8 - Direction of rotation"

- Check the seating of the fastening screws.

4.6.3 Teach-in run for the drive force

Depending on the drive and door, the drive system learns the maximum drive force required during the first movements after adjusting or changing the door positions.

- Move the drive system (with coupled gear unit) 3x from the door position CLOSED to the door position OPEN and back without interruption.

The drive force must be tested by qualified specialist personnel with a closing force measuring device designed for this purpose.

4.6.4 Check of the automatic shutoff

WARNING!

Risk of injury due to operation without automatic shutoff!

In order to guarantee personnel protection, the drive is equipped with an automatic shutoff.

Only if the correct function of the automatic shutoff is guaranteed may the product be operated.

- Check the automatic shutoff with OPEN and CLOSE.

Automatic shutoff OPEN

- Whilst the door is running, load the door in the centre of the lower edge with a mass of 20 kg:
The door must stop immediately.

Automatic shutoff CLOSE

- Place a 50 mm tall obstacle on the floor.
- Drive the door towards the obstacle:
The drive system must stop and reverse when it meets with the obstacle.

The drive force settings OPEN and CLOSE continue to be stored after the mains voltage is interrupted.

Only a reset will restore the parameters to the factory settings.

→ "Level 1, Menu 8 - RESET"

4.6.5 Check of the light barrier

- Check all light barriers individually by triggering the function.
- Check all closing edge protective devices individually by triggering the function.

4.7 Special programming

WARNING!

Risk of injury due to incorrectly set door forces!

In order to guarantee personnel protection, the door forces must remain within certain limit values. With a change in the parameters, these limit values may be exceeded. After a change in the settings, the door forces must therefore be checked to guarantee safe operation.

- Check the automatic shutoff.
- "4.6.4 Check of the automatic shutoff"
- Commission qualified specialist personnel with testing the drive force using a closing force measuring device designed for this purpose.

After a reset, all parameters are restored to the factory settings. Connected and functional safety elements are newly detected after the reset.

Additional connected accessories must be reprogrammed after a reset. To guarantee faultless operation of the control:

- Reprogram all desired functions.
- Reteach the remote control.
- Move the drive system into the door position OPEN and CLOSED once.

A connected light barrier is automatically detected by the control as soon as the power supply is connected. The light barrier can be retrospectively reprogrammed.

Light barriers that are not desired must be disconnected before the power supply is connected, otherwise the control will detect them.













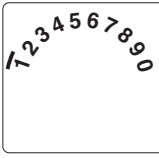

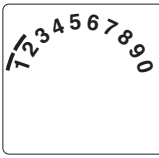
→ "3.6.5 Connection XP69A"

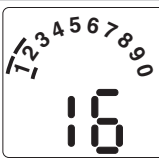

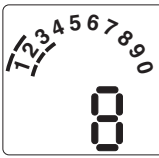

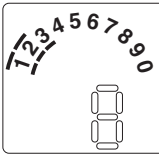
✓ After changes to the programming mode it is necessary to perform a function test.

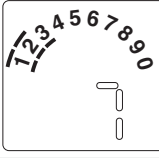
→ "4.6 Function test"

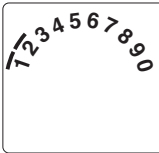
4.7.1 Programming the special functions

Programming process

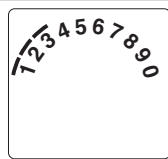
1.		Control is in operating mode.	
2.		P > 10 sec.: Start programming the extended drive functions. Display of the levels.	
3.	 	Selection of the desired level (example level 2).	
4.		Confirmation of the desired level. Display of the first menu and the set parameters.	
5.	 	Selection of the desired menu (example menu 3).	
6.		Confirmation of the desired menu. Display of the set parameter.	
7.	 	Change to the set parameter.	
8.		Save the parameter. The control changes to the level display	

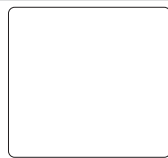
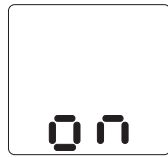
Programming process			
	 	Selection of the next desired level. Continue programming.	
or			
9.		P > 5 sec.: End programming. All changed parameters are saved.	
		Control is in operating mode.	

Level	Menu
6 Variable Speed	1 Speed OPEN
	2 Speed soft running OPEN
	3 Soft running position OPEN
	4 Speed CLOSE
	5 Speed smart running CLOSE
	6 Speed soft running CLOSE
	7 Smart running position CLOSE
	8 Soft running position CLOSE
	9 Soft start time OPEN
	10 Soft start time CLOSE
7 Service and maintenance	1 Door cycle counter
	2 Maintenance counter
	3 Maintenance interval
	8 Reset error memory
	9 Error display
8 System settings	1 Light barrier
	2 Closing edge protective device
	3 Automatic shutoff function
	4 Operating modes
	5 Direction command transmitter function
	6 Pulse command transmitter function
	7 Force release in DOOR CLOSED position (back-jump)
	8 Direction of rotation
	10 Position of the frame light barrier

4.7.2 Overview of the special functions

Level	Menu
1 Basic functions	1 Signal light output XH19
	3 Intermediate position OPEN
	4 Intermediate position CLOSE
	7 Signal light output XH79
	8 RESET
	9 Limit positions - fine adjustment OPEN
	10 Limit positions - fine adjustment CLOSE
2 Drive settings	1 Required drive force OPEN
	2 Required drive force CLOSE
	3 Automatic shutoff OPEN
	4 Automatic shutoff CLOSE
3 Automatic closure	1 Automatic closure
	3 Door open time
	4 Warning time
	5 Start-up warning
	7 Signal light
4 Radio programming	2 Intermediate position OPEN
	3 Intermediate position CLOSE
	4 OPEN
	5 CLOSED
	8 External lighting, wipe pulse approx. 1 second
5 Special functions	1 Programmable input XB50
	3 Programmable input XB90
	4 Lighting time
	7 Battery back-up
	8 Electric lock version

4.7.3 Contents of the special functions

Level 1 – Basic functions

Menu 1 – Signal light output XH19

1	Signal light → "Level 3, Menu 7 - Signal light"
2	OPEN position
3	CLOSED position
4	Intermediate position OPEN
5	Intermediate position CLOSE
6	Drive system starts (wipe pulse 1 second)
7	Fault
8	 Lighting (3-min. light) → "Level 5, Menu 4 - Lighting time"
9	Locking release (drive system running)
10	Locking release (drive system standstill)
11	Lock release (drive system starts / wipe pulse 3 seconds)
12	no function
13	Radio remote control (relay switches for the duration of the pulse) → "Level 4, Menu 8 - External lighting, wipe pulse approx. 1 second"
14	Test pulse for closing edge protective device (relay issues a test pulse and switches for 300 ms)

Menu 3 – Intermediate position OPEN

Setting with button + (OPEN) and – (CLOSE).
Closing function with automatic closure is possible.
→ "4.6.3 Teach-in run for the drive force"

Menu 4 – Intermediate position CLOSE

Setting with button + (OPEN) and – (CLOSE).
Closing function with automatic closure is not possible.
→ "4.6.3 Teach-in run for the drive force"

Level 1 – Basic functions

Menu 7 – Signal light output XH79

1	 Signal light → "Level 3, Menu 7 - Signal light"
2	OPEN position
3	CLOSED position
4	Intermediate position OPEN
5	Intermediate position CLOSE
6	Drive system starts (wipe pulse 1 second)
7	Fault
8	Lighting (3-min. light) → "Level 5, Menu 4 - Lighting time"
9	Locking release (drive system running)
10	Locking release (drive system standstill)
11	Lock release (drive system starts / wipe pulse 3 seconds)
12	no function
13	Radio remote control (relay switches for the duration of the pulse) → "Level 4, Menu 8 - External lighting, wipe pulse approx. 1 second"
14	Test pulse for closing edge protective device (relay issues a test pulse and switches for 300 ms)

Menu 8 – RESET

It is possible to reset the drive system to the factory settings.

1	 No reset
2	Resetting the controller (factory settings) Connected modules (BUS modules, bi-linked) must be reset separately.
3	Reset remote control (telegrams are deleted)
4	Reset expansion automatic closure → "Level 3 - Automatic closure"
5	Reset only expanded drive functions (apart from position OPEN/CLOSED and remote control pulse)
6	Reset safety elements (light barrier / hold circuit)
7	Reset bus modules (connected bus modules are taught)
8	Reset limit position settings The reset must take place with the door closed. The quick programming must be performed after a reset.

Level 1 – Basic functions

Menu 9 – Limit positions - fine adjustment OPEN

Increase or reduce the value with the + or – buttons.
If a positive value is displayed the limit position moves further in the OPEN DOOR direction.
If a negative value is displayed the limit position moves in the door centre direction.

 -8

Menu 10 – Limit position fine adjustment CLOSE

Increase or reduce the value with the + or – buttons.
If a positive value is displayed the limit position moves in the door centre direction.
If a negative value is displayed the limit position moves further in the CLOSE DOOR direction.

 8

Level 2 – Drive settings

Menu 1 – Required drive force OPEN

Sensitivity in steps from 1 - 16
(the higher the step, the higher the drive force).

 8

Menu 2 – Required drive force CLOSE

Sensitivity in steps from 1 - 16
(the higher the step, the higher the drive force).

 8

Menu 3 – Automatic shutoff OPEN

Sensitivity in steps from 1 (OFF) - 16
(the lower the step, the more sensitive the automatic shutoff).

 10

Menu 4 – Automatic shutoff CLOSE

Sensitivity in steps from 1 (OFF) - 16
(the lower the step, the more sensitive the automatic shutoff).

 10

Level 3 - Automatic closure

Menu 1 – Automatic closure

When activating automatic closure, the signal light connection XH19 (level 1 / menu 1) is automatically reset to the factory settings. If necessary, this can be subsequently reprogrammed.

1	 Deactivated	
2	Open time 15 / warning time 5	Extension of the open time only with pulse (Button, hand-held transmitter).
3	Open time 30 / Warning time 5	
4	Open time 60 / Warning time 8	
5	Open time 15 / Warning time 5	Open time cancelled only by passing through the light barrier.
6	Open time 30 / Warning time 5	
7	Open time 60 / Warning time 8	
8	Open time endless / Warning time 3	Close after passing through the light barrier / closure prevention.

Menu 3 – Door open time

2 – 250 seconds in steps.
 Depending on level 3, menu 1

Menu 4 – Warning time

1 – 70 seconds in steps.
 Depending on level 3, menu 1

Menu 5 – Start-up warning

0 – 7 seconds.
 0

Level 3 - Automatic closure

Menu 7 – Signal light

1	 Door movement / warning: flashing Door standstill: Off (energy saving)
2	Door movement / warning: illuminated Door standstill: Off (energy saving)
3	Door movement / warning: flashing Door standstill: flashing
4	Door movement / warning: illuminated Door standstill: illuminated
5	Door movement / warning: flashing Door standstill: illuminated
6	Door movement / warning: illuminated Door standstill: flashing
7	Door movement / warning: Pulsed tone Door standstill: Off
8	Door movement / warning: Continuous tone Door standstill: Off
9	Door movement / warning: Pulsed tone Door standstill: Pulsed tone
10	Door movement / warning: Continuous tone Door standstill: Continuous tone
11	Door movement / warning: Pulsed tone Door standstill: Continuous tone
12	Door movement / warning: Continuous tone Door standstill: Pulsed tone

Level 4 – Radio programming

Menu 2 – Intermediate position OPEN

Parameter display flashes -> Actuate hand-held transmitter button -> Hand-held transmitter display flashes -> The function has been taught.

Menu 3 – Intermediate position CLOSE

Parameter display flashes -> Actuate hand-held transmitter button -> Hand-held transmitter display flashes -> The function has been taught.

Menu 4 – OPEN

Parameter display flashes -> Actuate hand-held transmitter button -> Hand-held transmitter display flashes -> The function has been taught.

Menu 5 – CLOSE

Parameter display flashes -> Actuate hand-held transmitter button -> Hand-held transmitter display flashes -> The function has been taught.

Level 4 – Radio programming

Menu 8 – External lighting, wipe pulse approx. 1 second

Parameter display flashes -> Actuate hand-held transmitter button -> Hand-held transmitter display flashes -> The function has been taught.
The "lighting" parameter must be programmed.
→ "Level 1, Menu 7 - Signal light output XH79"

Level 5 – Special functions

Menu 1 – Programmable input XB50 (terminal B5/8)

1	 Pulse (NO only)
2	Pulse Remote Control (NO only)
3	Automatic closure ON/OFF
4	Stops and reverses (only CLOSE direction – NC only)
5	Stops and reverses (only CLOSE direction – NO only)
6	OPEN pulse (NO only)
7	Stop (NC only)
8	Premature closing through actuation of button or hand-held transmitter > 2 seconds
9	Intermediate position OPEN (NO only)
10	Intermediate position CLOSE (NO only)

Menu 3 – Programmable input XB90 (terminal B9/8)

1	 Pulse (NO only)
2	Pulse Remote Control (NO only)
3	Automatic closure ON/OFF
4	Stops and reverses (only CLOSE direction – NC only)
5	Stops and reverses (only CLOSE direction – NO only)
6	OPEN pulse (NO only)
7	Stop (NC only)
8	Premature closing through actuation of button or hand-held transmitter > 2 seconds
9	Intermediate position OPEN (NO only)
10	Intermediate position CLOSE (NO only)

Menu 4 – Lighting time

2 – 250 seconds in steps.
 3.0 (180 seconds)

Level 5 – Special functions

Menu 7 – Battery back-up

1	 Battery back-up deactivated
2	Battery back-up active

Menu 8 – Electric lock version

1	 Electric lock (Electric lock active with drive start for 3 seconds)
2	Electric lock / magnetic locking (Electric lock / magnetic locking inactive with drive start for 3 seconds)
3	Electric lock with locking pin (Electric lock active with drive start)
4	Lockmatic electric lock (Electric lock inactive with drive start)

Level 6 - Variable speed

Smart running is only usable for doors bigger than 3000 mm. Smart running is set such that the drive travels slower when closing in the CLOSE direction from a height of 2500 mm, so that the forces per the standard are complied with. Above 2500 mm it is possible to travel at max. speed.

Menu 1 – Speed OPEN

Steps from 5 - 16.
 16

Menu 2 – Speed soft running OPEN

Steps from 1 - 16.
 8

Menu 3 – Soft running position OPEN

Setting with button + (OPEN) and – (CLOSE).

Menu 4 – Speed CLOSE

Steps from 1 - 16.
 12

Level 6 - Variable speed

Menu 5 – Speed smart running CLOSE

Steps from 5 - 16.
 9

Menu 6 – Speed soft running CLOSE

Steps from 1 - 16.
 8

Menu 7 – Smart running position CLOSE

Setting with button + (OPEN) and – (CLOSE).

Menu 8 – Soft running position CLOSE

Setting with button + (OPEN) and – (CLOSE).

Menu 9 – Soft start time OPEN

1	Soft start time 1 second
2	Soft start time 2 seconds
3	 Soft start time 3 seconds
4	Soft start time 6 seconds

Menu 10 – Soft start time CLOSE

1	Soft start time 1 second
2	Soft start time 2 seconds
3	 Soft start time 3 seconds
4	Soft start time 6 seconds

Level 7 – Service and maintenance

Menu 1 – Door cycle counter

Six-digit display of the door actuations up to 999999. Digits consecutively until display of point, then repeated.

Menu 2 – Maintenance counter

Five-digit display of the remaining door actuations until maintenance display. Digits consecutively until display of point, then repeated.

Level 7 – Service and maintenance

Menu 3 – Maintenance interval

Setting the number of door actuations from which required maintenance is displayed.

1	 OFF
2	100 door actuations
3	500 door actuations
4	1,000 door actuations
5	4,000 door actuations
6	5,000 door actuations
7	6,000 door actuations
8	7,000 door actuations
9	8,000 door actuations
10	9,000 door actuations
11	10,000 door actuations
12	15,000 door actuations
13	20,000 door actuations
14	30,000 door actuations
15	40,000 door actuations
16	50,000 door actuations

Menu 8 – Reset error memory

The error memory is reset here for service, diagnostics and maintenance work.

In case of service:

Before deleting, make a note of the existing error messages for any queries.



Note:

Deleting the error memory can take up to 10 seconds, only then are no errors present in the list.

1	 No reset
2	Reset error memory

Menu 9 – Error display

Display of the current error message (max. 16 error indications possible).

	Display of the previous error / Navigation through the error list
	Navigation through the error list

Level 8 – System settings

Door reverses for a brief time:

The drive system briefly moves the door in the opposite direction to release an obstacle.

Door reverses for extended time:

The drive system moves the door into the OPEN position.

Menu 1 – Light barrier

1	 Operation without light barrier
2	2-wire light barrier (Connection XP69A - terminal P6/27), CLOSE door movement: Door reverses for extended time
3	External light barrier (Connection XP69A - terminal P6/27), CLOSE door movement: Door reverses for extended time

Level 8 – System settings

Menu 2 – Closing edge protective device

1	 OPEN door movement: Door reverses for a brief time CLOSE door movement: Door reverses for a brief time
2	OPEN door movement: Door reverses for a brief time CLOSE door movement: Door reverses for extended time
3	OPEN door movement: Door reverses for extended time CLOSE door movement: Door reverses for a brief time
4	OPEN door movement: Door reverses for extended time CLOSE door movement: Door reverses for extended time
5	OPEN door movement: Door reverses for a brief time with pressure switch testing CLOSE door movement: Door reverses for a brief time with pressure switch testing
6	OPEN door movement: Door reverses for a brief time with pressure switch testing CLOSE door movement: Door reverses for extended time with pressure switch testing
7	OPEN door movement: Door reverses for extended time with pressure switch testing CLOSE door movement: Door reverses for a brief time with pressure switch testing
8	OPEN door movement: Door reverses for extended time with pressure switch testing CLOSE door movement: Door reverses for extended time with pressure switch testing

Level 8 – System settings

Menu 3 – Automatic shutoff function

1	 OPEN door movement: Door stops CLOSE door movement: Door reverses for a brief time
2	OPEN door movement: Door reverses for a brief time CLOSE door movement: Door reverses for a brief time
3	OPEN door movement: Door stops CLOSE door movement: Door reverses for extended time
4	OPEN door movement: Door reverses for extended time CLOSE door movement: Door reverses for extended time

Menu 4 – Operating modes

1	OPEN door movement: Dead-man CLOSE door movement: Dead-man
2	OPEN door movement: Self-locking CLOSE door movement: Dead-man
3	OPEN door movement: Dead-man CLOSE door movement: Self-locking
4	 OPEN door movement: Self-locking CLOSE door movement: Self-locking

Menu 5 – Direction command transmitter function

1	Direction command transmitter not active: The direction command transmitters only trigger a command with a stationary door.
2	 Direction command transmitter STOP only: A running door is stopped by each direction command transmitter.

Level 8 – System settings

Menu 6 – Pulse command transmitter function

1	Pulse command transmitter not active: The pulse command transmitters only trigger a command with a stationary door.
2	Pulse command transmitter STOP only, then standard sequence: A running door is stopped by each pulse command transmitter. A command sequence starts the drive system in the opposite direction (OPEN - STOP - CLOSE - STOP - OPEN). With automatic closure, STOP is possible in OPEN direction.
3	 Pulse command transmitter STOP only, then standard sequence: A running door is stopped by each pulse command transmitter. A command sequence starts the drive system in the opposite direction (OPEN - STOP - CLOSE - STOP - OPEN). With automatic closure, no STOP in OPEN direction.

Menu 7 – Force release in DOOR CLOSED position (back-jump)

1	 Back-jump not active
2	Back-jump active – for a brief time
3	Back-jump active – moderate time
4	Back-jump active – extended time

Menu 8 – Direction of rotation

Reversing the direction of rotation is only permissible in the CLOSED door position.

The quick programming OPEN menu is displayed automatically.
Drive the door for min. 2 seconds without interruption in the OPEN door direction.

1	 Standard
2	Reverse direction of rotation After changing the direction of rotation, a RESET of the limit positions takes place automatically.

Menu 10 – Position of the frame light barrier

The position of the frame light barrier can be set manually if necessary.

Setting with button + (OPEN) and – (CLOSE).

5. Operation

5.1 Safety instructions for operation

WARNING!

Danger due to a failure to comply with the operating instructions!

This chapter contains important information for safe operation of the product.

- Read this chapter through carefully before operation.
- Follow the safety instructions.
- Use the product as described.

5.2 Operating systems

The door system can be operated using the following control systems:

- Code modulator
- Transponder
- Coin validator
- Induction loop
- Hand-held transmitter / radio equipment

 Observe the corresponding instructions for using the controls.

5.3 Emergency operation

WARNING!

Risk of burns due to incorrect operation!

In order to avoid personal injury, the following points must be observed:

- Emergency operation must take place whilst standing on a stable foundation.
- Emergency operation shall only take place with the motor at a standstill.
- The system must be disconnected from the power supply during emergency operation.

With an electrical fault or during maintenance work, the door can be moved with the aid of the OPEN and CLOSE emergency operation.

If the door moves beyond the OPEN or CLOSE limit positions, the drive can no longer be electrically operated.

5.3.1 Drive with emergency hand chain

5.3.1 / 1

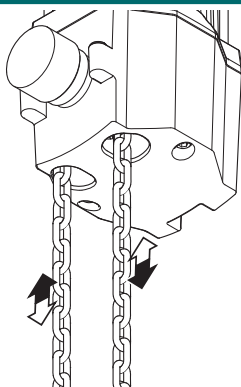

- Release the emergency hand chain from the safety catch.
- Drive the door in the OPEN or CLOSE direction by pulling the emergency hand chain on the corresponding side.

5.3.2 Drive with emergency hand crank

5.3.2 / 1

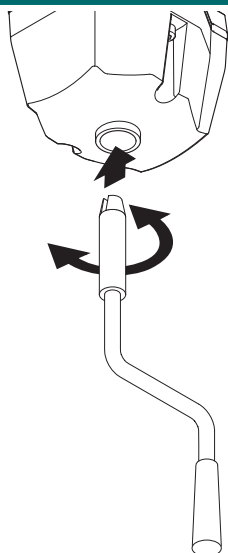

- Plug the emergency hand crank into the drive up to the stop.
- Drive the door in the OPEN or CLOSE direction by turning the emergency hand crank.
- After emergency actuation is complete, remove the crank again.

5.3.3 Drive with unlocking

WARNING!

Risk of injury due to uncontrolled door movement!

To avoid personal injury, fall protection must be fitted to the door in case of gear units with unlocking.

If no fall protection is installed, the door does not comply with directive ASR A1.7.

5.3.3 / 1

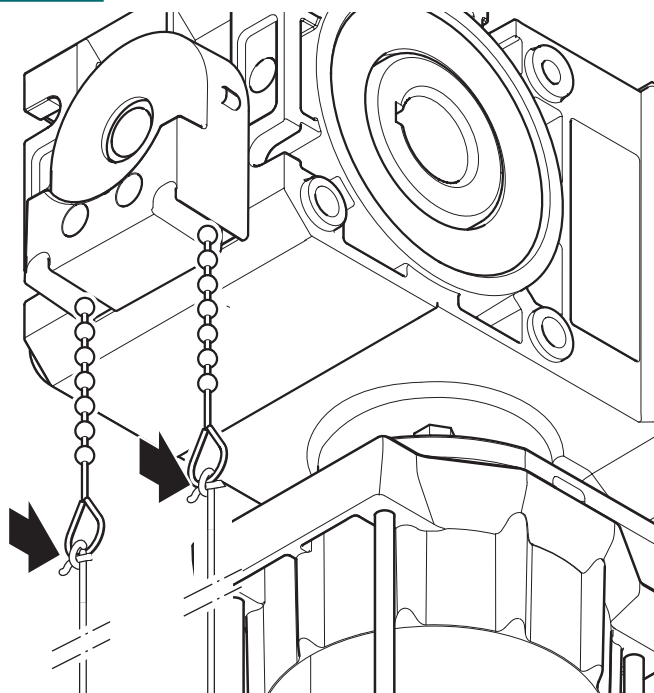

- Attach the rope cable supplied to the unlocking loops.

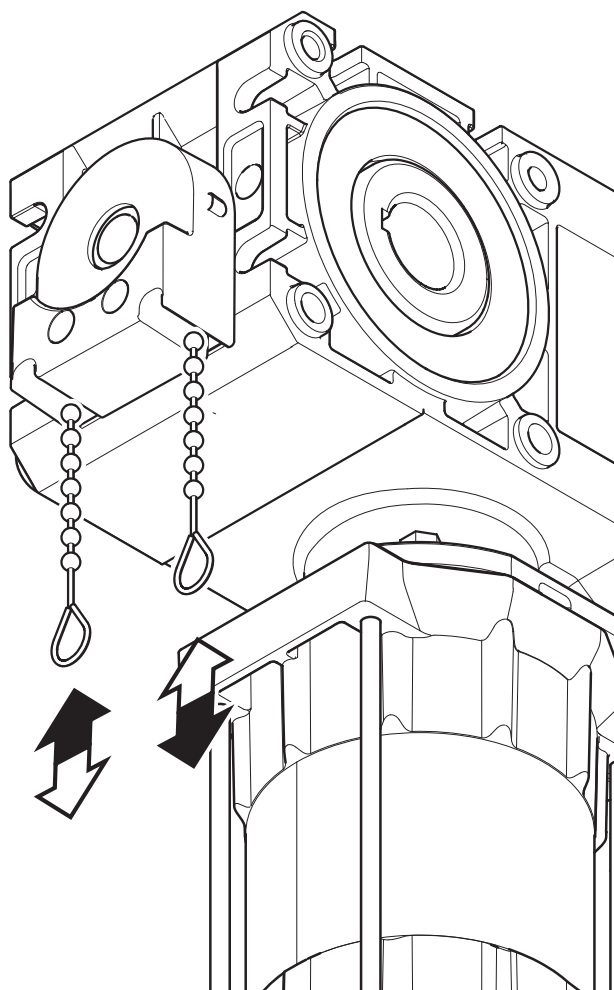

- Pull on the red cable toggle.
The door can be moved manually.
- Pull on the green cable toggle.
The door can be moved with the drive.

6. Care

WARNING!

Life-threatening danger due to electric shock!

Touching live parts can lead to an electric shock, burns or death.

- Make sure that the power supply is and remains disconnected for the duration of cleaning work.

ATTENTION!

Risk of property damage due to improper handling!

Never clean the drive using:

direct water jet, high pressure cleaner, acids or alkalis.

- Only use a soft non-linting cloth for cleaning.

In case of severe soiling, the housing can be cleaned with a mild cleaning solution.

- Clean the housing exterior using a damp cloth.

7. Maintenance

Maintenance by qualified specialist personnel only.
→ "1.2.2 Specialist personnel"

WARNING!

Risk of injury due to electric shock!

There is a danger of electric shock in case of contact with the mains voltage.

- Prior to maintenance work, always disconnect the drive system from the power supply.
- Ensure that the power supply remains disconnected for the duration of the maintenance work.

ATTENTION!

Risk of property damage due to improper maintenance of the drive!

In order to avoid damage to the drive and door, observe the following points:

- Directive ASR A1.7 must be complied with.
- Worn or faulty parts must be replaced.
- Only approved parts may be installed.
- All maintenance work must be documented.

The gear is lifetime lubricated and maintenance-free.
The hollow shaft must be kept free of rust.

- Check that all fastenings are securely seated.
- Check the spring tension on the door.
- The springs must be set such that the weight is balanced.
- Check the brake (if available).
- Check the limit switches and safety switches.
- Check for noise and oil loss.
- Check the drive fastening for corrosion.
- Check the housing for damage.

Replaced faulty parts must be disposed of properly in accordance with the materials they contain and local regulations.

8. Disassembly

Disassembly by qualified specialist personnel only.
→ "1.2.2 Specialist personnel"

WARNING!

Life-threatening danger due to electric shock!

Touching live parts can lead to an electric shock, burns or death.

- Make sure that the power supply is and remains disconnected for the duration of the disassembly work.

WARNING!

Risk of injury due to incorrect handling!

The size and weight of the product require extensive force during disassembly. If the product falls, this may cause serious injuries.

- Secure the drive system against falling prior to disassembly.
- Observe all applicable occupational safety provisions.

Disassembly takes place in reverse order to installation.

→ "3. Installation"

9. Disposal

Disposal by qualified specialist personnel only.
→ "1.2.2 Specialist personnel"

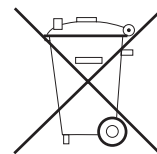

Used devices and batteries must not be disposed of with household waste!

- Dispose of used devices at a collection point for electronic scrap or via your specialist dealer.
- Dispose of used batteries in a recyclables container for used batteries or via a specialist dealer.
- Dispose of packaging materials in a recycling container for cardboard, paper and plastic.

10. Troubleshooting

Faults without error message display

Command 108 has no display and does not light up.

No power.

- Check whether mains voltage is present.
- Check power connection.

Thermal protection in the mains power supply has triggered.

- Leave mains power supply to cool down.

Control unit defective.

- Have the drive system checked.

No reaction after pulse.

Connection terminals for "pulse" button bridged, e.g. through line short circuit.

- Experimentally disconnect any wired key switch or internal pressure switch from the control unit: Disconnect cable from XB50 socket and locate wiring fault.
- "3.6.2 Connection XB50"

No reaction after pulse by hand-hand transmitter.

Module antenna not plugged in.

- Connect module antenna with control unit.

Hand-held transmitter coding does not match with receiver coding.

- Reactivate hand-held transmitter.
- "4.4 Factory settings"

Hand-held transmitter battery empty.

- Insert new battery.
- "5. Operation"

Hand-held transmitter or control electronics or module antenna defective.

- Have all 3 components checked.

Faults with error message display

The display shows detected faults with an error number (example error number 7).

The control changes to message mode.

In operating mode, it is possible to display the last error number by pressing the P button.

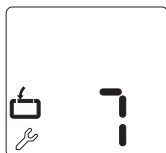

Error number 5

The closing edge protective device was actuated in the CLOSE direction.

- Check door, if necessary remove obstacle.

Faults with error message display

Error number 7

Programming mode ends automatically after 120 seconds of no button actuation, or with an error during programming.

- Restart the programming process.

Error number 9

Limit position sensor pulse not available, Drive system jammed.

- Have the drive system checked.

Error number 10

Movement too sluggish or door jammed.

- Make door passable.

Maximum drive force set too low.

- Have maximum drive force checked by qualified specialist personnel using a closing force measuring device designed for this purpose.
- "Level 2, Menu 1 - Required drive force OPEN"
→ "Level 2, Menu 2 - Required drive force CLOSE"

Error number 11

Run time limiting.

- Have the drive system checked.

Error number 13

Test of the closing edge protective device in the CLOSE direction not OK.

- Have the closing edge protective device checked.

Closing edge protective device programmed in the CLOSE direction, but not connected.

- Deactivate closing edge protective device in the CLOSE direction, or connect.

Error number 15

Light barrier interrupted or defective.

- Remove obstacle or have light barrier checked.

Light barrier programmed, but not connected.

- Deactivate light barrier, or connect.

Error number 16

Current sensor for automatic shutoff defective.

- Have motor unit checked.

Faults with error message display

Error number 26

Under-voltage. Drive system overloaded with setting of the drive force at step 16 (maximum).

- Have external power supply checked.

Error number 28

Door movement too sluggish, irregular or jammed.

- Have door movement checked and make door passable.

Error number 30

MS-BUS error.

- Perform BUS module reset.
- "Level 1, Menu 8 - RESET"
- Have connected BUS modules checked.

Error number 33

Overload protection triggered, door too sluggish.

- Check door.

Overload protection triggered, door driven too often.

- Leave mains power supply to cool.

Error number 35

Electronics defective.

- Have the drive system checked.

Error number 36

This error number can also be triggered by a connected expansion module.

Connection terminals for "stop" button interrupted, e.g. through line interruptions.

- Experimentally disconnect wired stop button from the control: Disconnect cable from XB50 socket and locate wiring fault.
- "3.6.2 Connection XB50"

Error number 39

Limit position sensor defective.

- Check limit position sensor or have it replaced.

Error number 40

Safety limit positions approached or limit positions not programmed.

- Program limit positions.
- Drive door to the centre with emergency hand chain.

Faults with error message display

Error number 41

Limit position sensor speed error, door too sluggish.

- Have door checked.

Error number 43

The slackline protection has triggered.

- Check rope cables on the door.
- Perform a reset of the safety elements.
- "Level 1, Menu 8 - RESET"

Error number 44

8K2 hold circuit or connection terminals for the door hold circuit interrupted, e.g. through cable interruption.

- Disconnect cable from XP15 socket (WT / STOP terminal) and locate wiring fault.

Error number 48

Door movement too sluggish, irregular or door jammed.

- Check door movement and make door passable.

Setting of the CLOSE door positions defective.

- Check the OPEN and CLOSE door positions and readjust if necessary.
- Check door.

Faults with error message display CSI-15, LED H1 - green

LED is off, operating voltage missing

No power.

- Check whether mains voltage is present.
- Check power connection.

Faults with error message display CSI-15, LED H2 - red

2x flashing, error number 39

Limit position sensor defective.

- Check limit position sensor or have it replaced.

3x flashing, error number 40

Safety limit positions approached or limit positions not programmed.

- Program limit positions.
- Drive door to the centre with emergency hand chain.

5x flashing, error number 28

Door movement too sluggish, irregular or jammed.

- Have door movement checked and make door passable.

8x flashing, error number 41

Limit position sensor speed error, door too sluggish.

- Have door checked.

Continuous illumination, error number ...

With continuous illumination of red LED:

- Connect command 108 to XW40 to read the error number out of the control.

11. Annex

11.1 Manufacturer's declaration

Declaration of incorporation

in accordance with the Machinery Directive 2006/42/EC for the incorporation of an incomplete machine per Annex II, Part 1B.

Declaration of conformity

in accordance with the directives for electromagnetic compatibility 2014/30/EU and RoHS 2011/65/EU.

Manufacturer:

MFZ Antriebe GmbH & Co.KG, Neue Mühle 4,
D - 48739 Legden

We hereby declare that the product cited below

Product designation: **Sectional door drive**
Type designation: **VTA**

as an incomplete machine intended exclusively for incorporation in a door system and developed, designed and produced in accordance with the following directives:

- Machinery Directive 2006/42/EC
- Electromagnetic Compatibility Directive 2014/30/EU
- RoHS Directive 2011/65/EU

Furthermore, it also satisfies the requirements of the Low Voltage Directive 2014/35/EU per Annex I Part 1.5.1 of the satisfies Machinery Directive 2006/42/EC.

Applied standards:

EN 12453	Doors - Safety in use of power operated doors: Requirements and test methods
EN 12604	Doors - Mechanical aspects: Requirements and test methods
EN 60335-1	Safety of household and similar electrical appliances - Part 1: General requirements
EN 60335-2-103	Safety of household and similar electrical appliances - Part 2-103: Particular requirements for drives for gates, doors and windows
EN 61000-6-2	Electromagnetic compatibility (EMC) — Part 6-2: Generic standards – Immunity for industrial environments
EN 61000-6-3	Electromagnetic compatibility (EMC) — Part 6-3: Generic standards – Emission standard for residential, commercial and light-industrial environments

The relevant technical documentation has been compiled in accordance with Annex VII, part B of the Machinery Directive (2006/42/EC). We undertake to transmit, in response to a reasoned request by the market surveillance authorities, this information in electronic form within a reasonable term.

Person authorised to compile the technical documentation:
MFZ Antriebe GmbH & Co. KG - Neue Mühle 4 - 48739 Legden -
Germany

Incomplete machines in accordance with the EC directive 2006/42/EC are only intended for incorporation in other machines or incomplete machines or systems or for combination with them, in order to form a machine with them in accordance with the aforementioned directive. This product must therefore not be put into service until the complete machine / system into which it is incorporated is compliant with the provisions of the aforementioned EC directives.

A change to this product that has not been approved by us results in this declaration losing its validity.

Legden, 03.02.2020



Dirk Wesseling, Management

