

I-770

INSTALLATION INSTRUCTIONS AND SAFETY INFORMATION SINGLE AND DUAL GATE SYSTEMS

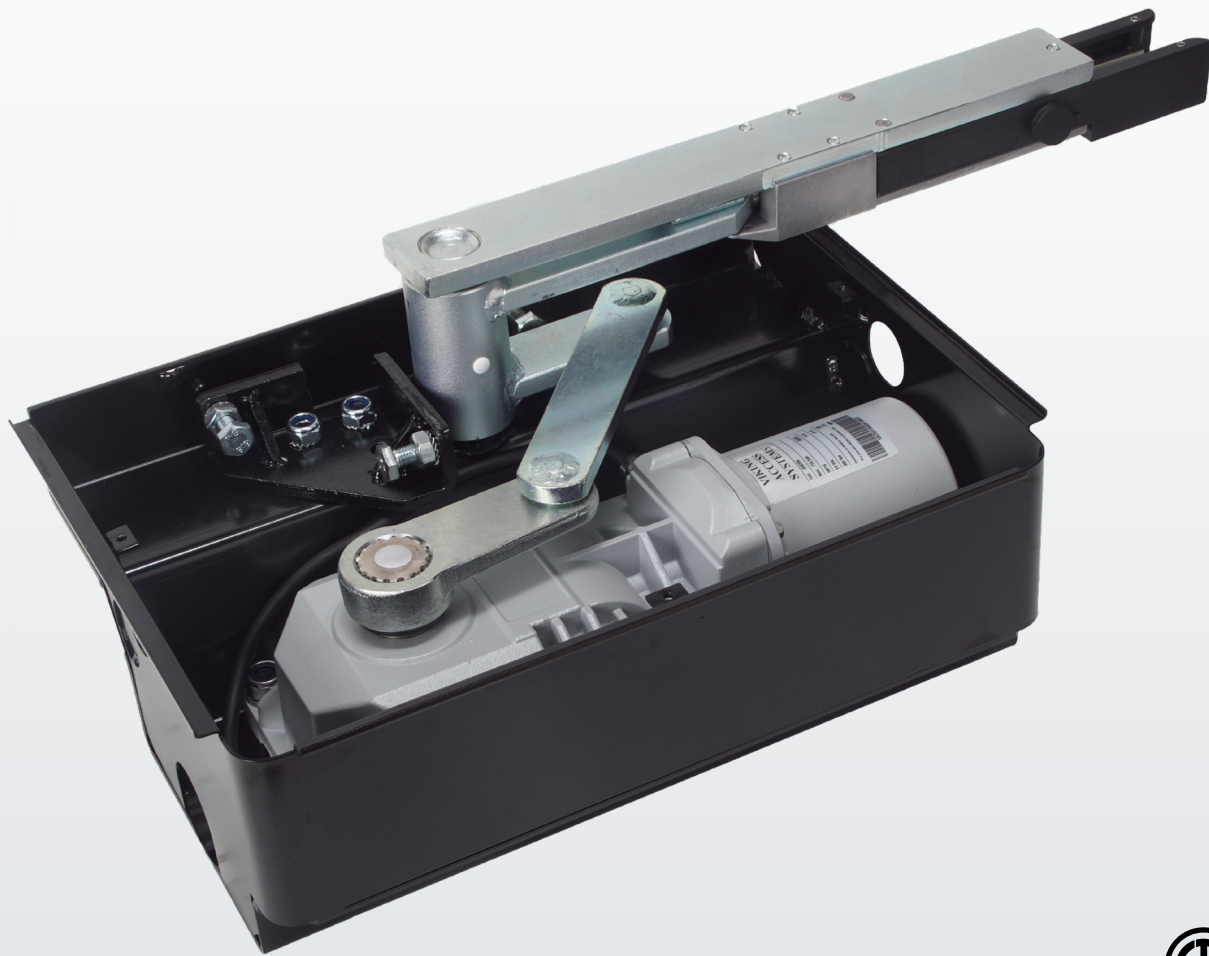

CLASS I, CLASS II, CLASS III,
AND CLASS IV
**Residential and Commercial
Vehicular Swing Gate Operator**



VIKING ACCESS SYSTEMS™

VIKING ACCESS SYSTEMS™

VIKING ACCESS SYSTEMS™

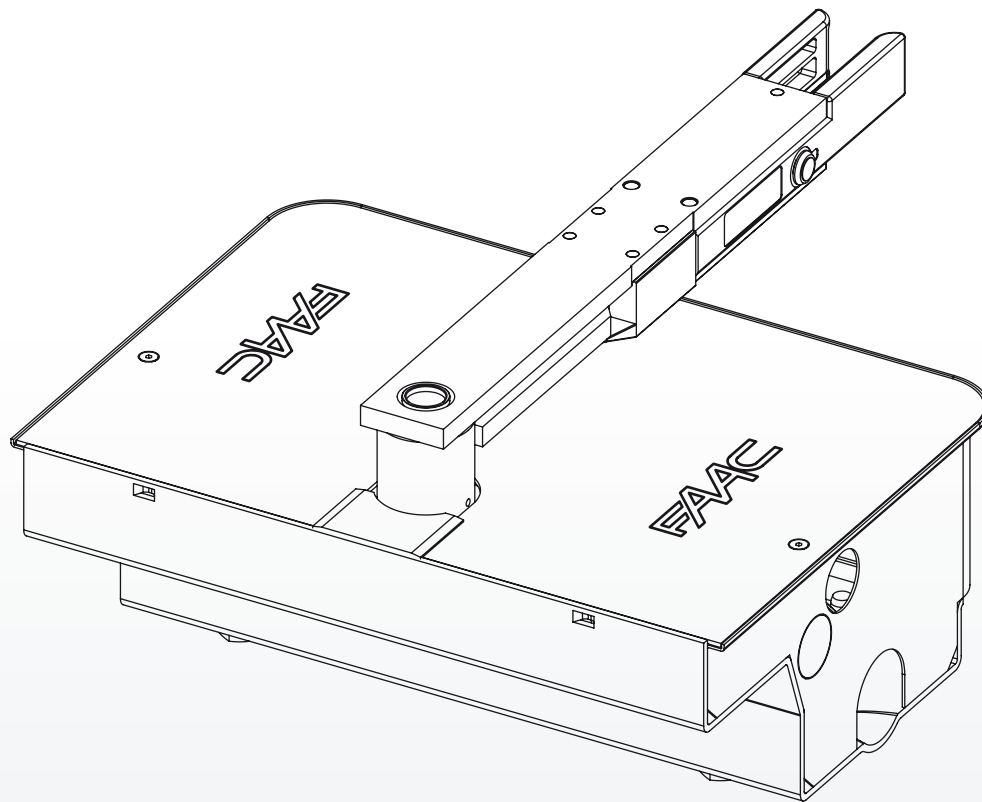

The answer for an elegant solution for access control is fulfilled with the I-770 gate operator. The discreteness of the installation, the flexibility of operation, the efficiency of automation, and the adaptability of integration makes the I-770 gate operator a perfect solution in situations where aesthetics are required to satisfy the most exquisite taste. The I-770 operator is now powered by the advanced intelligence and simplicity of our new VFlex control board!

THE VIKING I-770™ SWING GATE OPERATOR

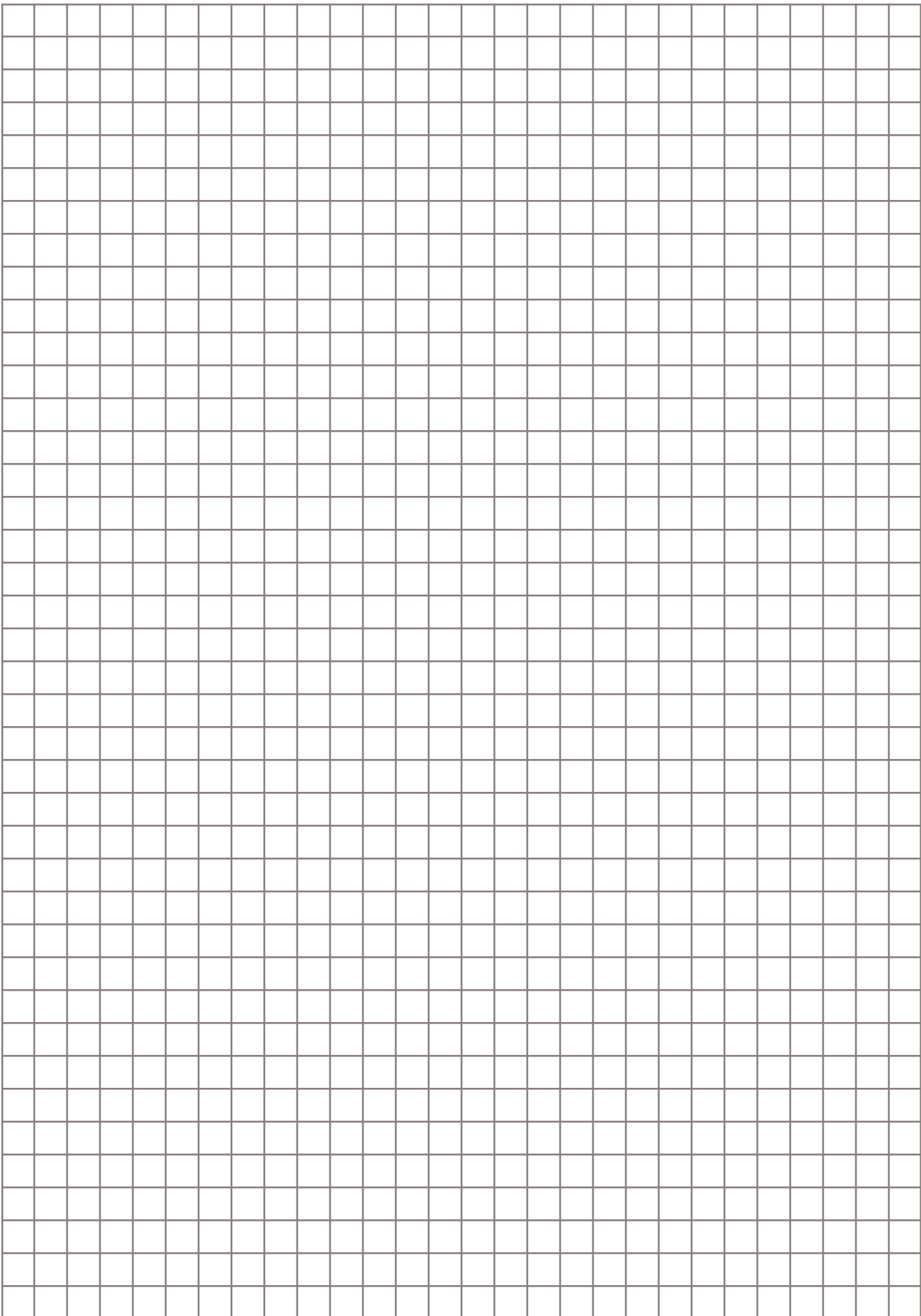
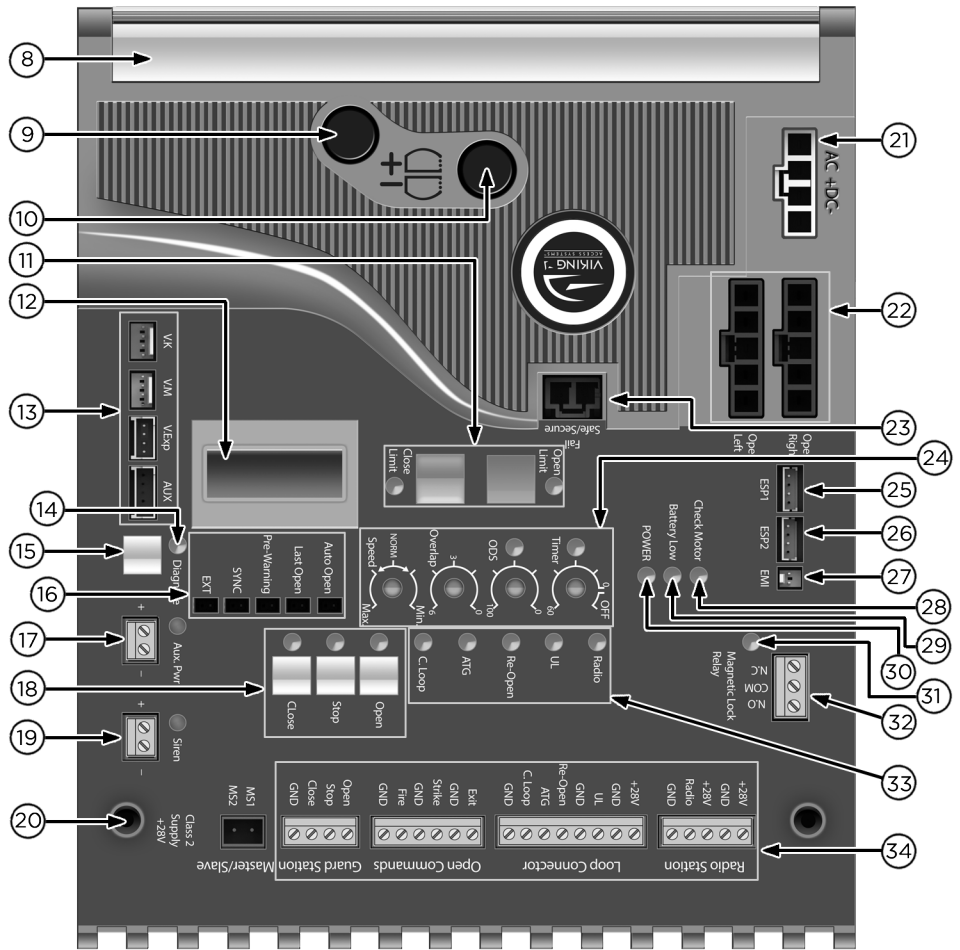
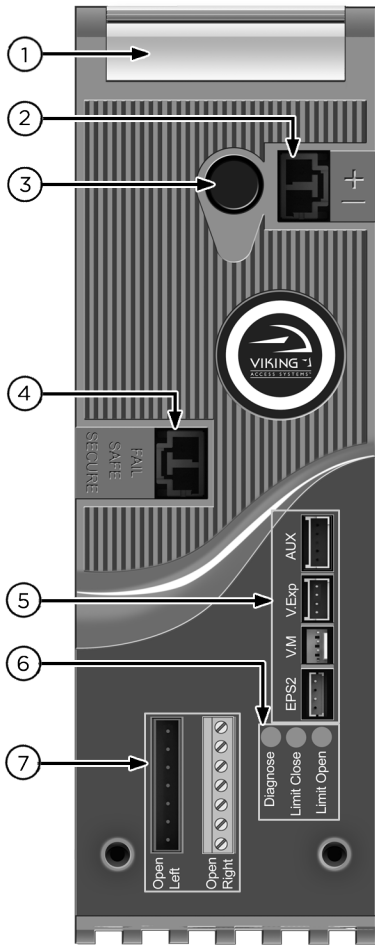

TABLE OF CONTENTS:

CONTROL BOARD REFERENCES	3
PARTS DIAGRAM/PARTS LIST - OPERATOR	4
PARTS DIAGRAM/PARTS LIST - CONTROLLER	5
IMPORTANT SAFETY INFORMATION	6-12
Important Safety Instructions.....	6
Important Installation Instructions.....	7
Maintenance.....	8
General Safety Precautions.....	8-9
Operator Classification.....	9
Entrapment Protection Requirements.....	10
Entrapment Protection Installation.....	11
Manual Release.....	11
Audible Alarm Reset Installation.....	12
Warning Placard Installation.....	12
IMPORTANT INSTALLATION INFORMATION	13
Specifications.....	13
GATE OPERATOR INSTALLATION	14-18
Plans of Installation.....	14-15
Installing the Gate Operator.....	16-17
Limits Setup.....	18
ECU BOX INSTALLATION	19
ELECTRICAL INSTALLATION	20-23
High Voltage Supply Option.....	20
Low Voltage Supply Option.....	21
Solar Supply Option.....	21
Motor Cable.....	22-23
LIMITS INDICATIONS	24
CONTROL BOARD SETUP	25-28
Initial Settings.....	25-26
Obstruction Detection Sensor (ODS).....	27
Heater.....	28
ACCESSORY CONNECTIONS	29-35
UL, Re-Open (Monitored Input Terminals).....	29
Radio Receiver (Typical).....	30
Anti-Tail Gate, Open Commands, Guard Station.....	31
Viking Loop Rack.....	32
Guidelines for Loop Installations.....	33
Magnetic Lock, Lock Solenoid.....	34
Barrier Arm Synchronization Option.....	35
TROUBLESHOOTING	36-41
LED References.....	36-37
LCD Display References.....	38-40
Solutions.....	41
APPENDIX A, B, C	42-45
VIKING EXPANSION PRODUCTS	48

CONTROL BOARD REFERENCES:



1. HEAT SINK - SECONDARY MODULE secures the control board and dissipates heat.
2. SECONDARY MODULE POWER HARNESS CONNECTOR provides power to the Secondary Module. pg 23
3. FUSE HOLDER - 15 AMP for the Secondary motor circuit.
4. "FAIL SAFE/SECURE" SECONDARY MODULE not applicable to this model.
5. M/S COMM CABLE CONNECTION - SECONDARY MODULE Primary/Secondary (dual) gate applications. pg 23
6. STATUS LEDs - SECONDARY MODULE provides diagnostic information.
7. SECONDARY MOTOR CONNECTION provides power to the Secondary motor. pg 23
8. HEAT SINK - PRIMARY secures the control board and dissipates heat.
9. FUSE HOLDER - 4 AMP for the charging circuit.
10. FUSE HOLDER - 15 AMP for the Primary motor circuit.
11. LIMIT SETUP BUTTONS available for future developments.
12. LCD DIAGNOSTICS DISPLAY provides error messages, diagnostics settings and operator status information. pg 38-40

13. M/S COMM CABLE CONNECTION - PRIMARY Primary/Secondary (dual) gate applications. pg 23
14. "DIAGNOSE" LED informs that errors have been detected and available on LCD Display. pg 40
15. "DIAGNOSE" Button allows you to navigate through the Diagnostics LCD Display. pg 38-40
16. FEATURE ACTIVATION PIN HEADERS activate features by placing a jumper onto the pin headers. pg 26
17. "AUX. PWR" Terminal Block used for solar applications & in-motion warning devices. pg 21, 26
18. ON-BOARD 3 BUTTON STATION controls the gate during set up.
19. "Siren" Terminal Block Vikings UL Siren is connected here. pg 12, 27
20. CONTROL BOARD MOUNTING HOLES secures and grounds the control board.
21. POWER HARNESS CONNECTOR provides power to the control board. pg 20
22. PRIMARY or SINGLE MOTOR CONNECTION provides power to the motor. pg 22
23. "FAIL SAFE/SECURE" Jumper not applicable to this model.

24. FEATURE ACTIVATION TRIM POTS activate and set features. pg 25
25. "EPS1" CONNECTOR available for future developments
26. "EPS2" CONNECTOR available for future developments
27. "EMI" BOARD CONNECTOR monitors the high voltage power supply.
28. "CHECK MOTOR" Status LED indicates motor power status. pg 36
29. "BATTERY LOW" Status LED indicates battery power status. pg 36
30. "POWER" Status LED control board power status. pg 20, 36
31. "MAGNETIC LOCK Relay" Status LED status of this on-board relay. pg 34, 36
32. "MAGNETIC LOCK Relay" Terminal Block connect electric locks here. pg 34, 36
33. INPUT STATUS LEDs indicates input status. pg 36-37
34. ACCESS CONTROL TERMINAL BLOCKS accessory connections. pg 29-32, 42-44

PARTS DIAGRAM - OPERATOR:

Item	Description	Part No.
1	Release Levers Kit With Locks	FA-63000422
2	Steel Ball	FA-63003015
3	Cover Plug	FA-7271985
4	Box Cover	FA-727157
5	Articulated Lever	FA-390477
6	Manual Release Assembly	FA-424010
7	Motor/Gear Assembly	FA-10675315
8	Close Limit Positive Stop Assembly	FA-755122
9	Open Limit Positive Stop Assembly	FA-722121

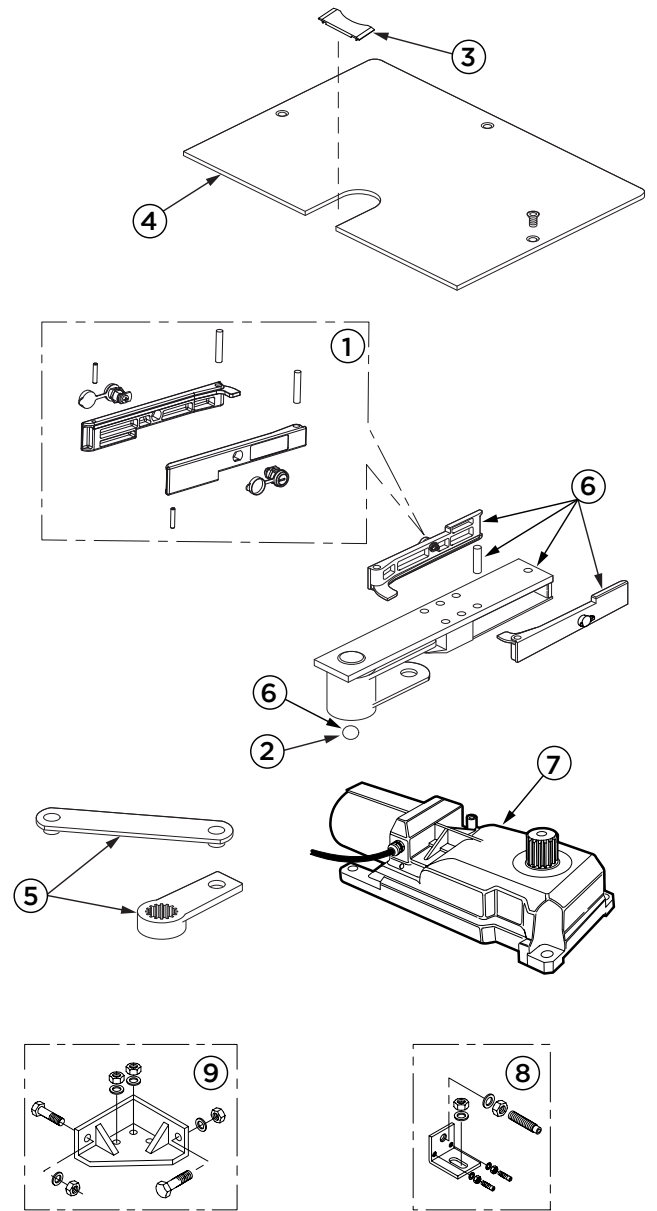
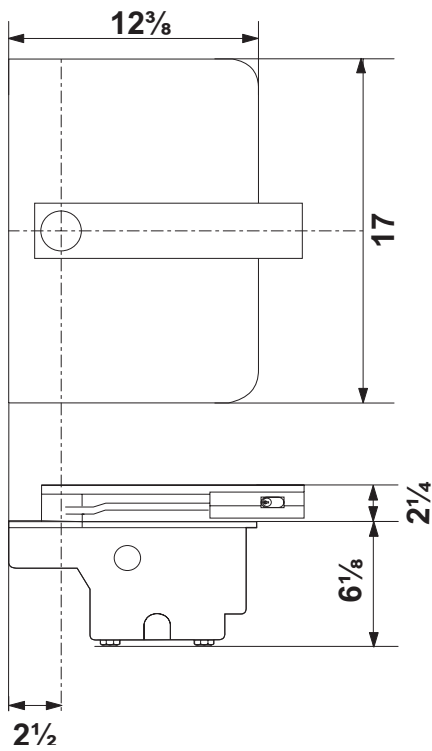

PARTS DIAGRAM - CONTROLLER:

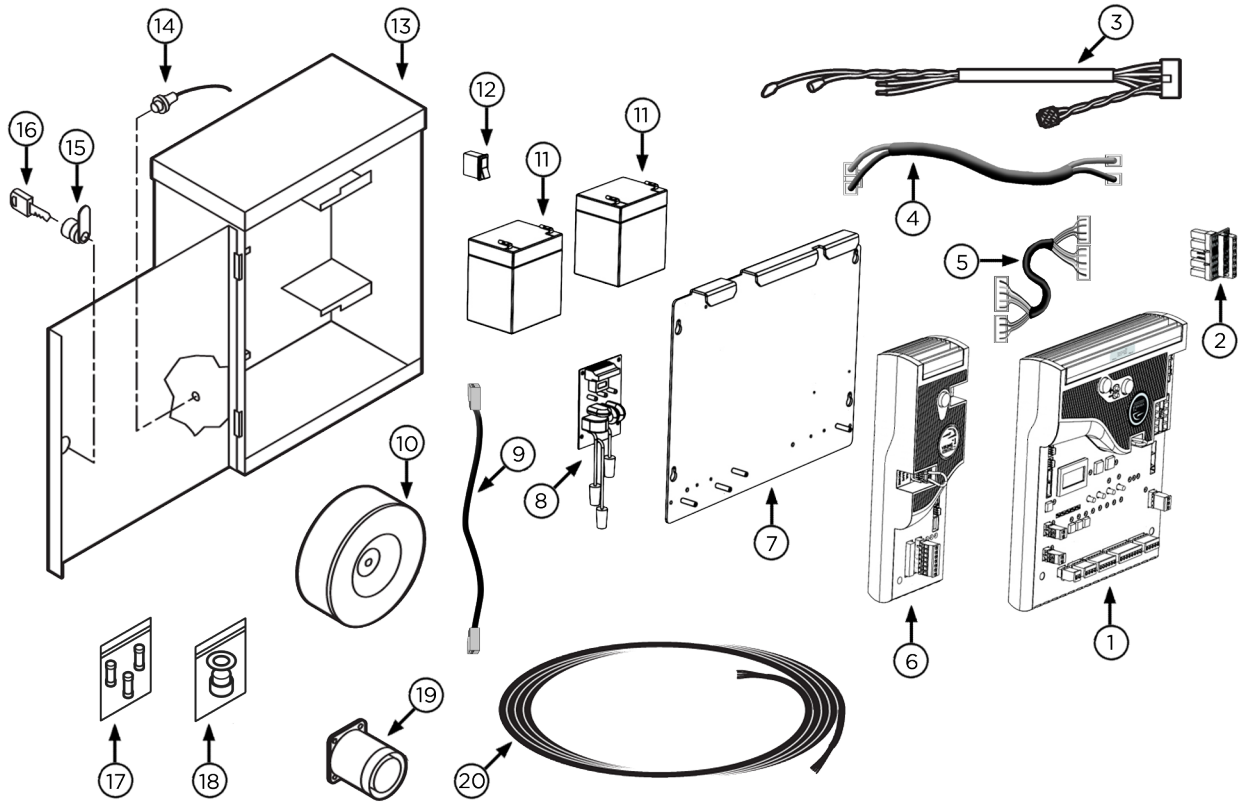

Item	Description	Part No.
1	Control Board - Primary	VFLEXPCBU18
2	Motor Connector - Primary	FAECUMCM77
3	Power Harness - Primary	DUPHCECU
4	Secondary Power Harness <i>(Dual Controller only)</i>	VECUSPH
5	Primary/Secondary Comm Cable <i>(Dual Controller only)</i>	VECUMSC
6	Secondary Module <i>(Dual Controller only)</i>	VFLEXSMU18
7	Board Mounting Plate	VECUBMP
8	EMI Board	DUEMI10
9	EMI Comm Cable	VWEMICC
10	Toroid Transformer - 10 amp	DUTT10
11	Battery	DUBB12
12	Battery Switch	DUMRS10
13	ECU Cabinet Chassis	VNXCUBB
14	Alarm Reset Switch	ECURW
15	ECU Key Cylinder & Key(s)	ECUKEYC20
16	ECU Access Key(s)	ECUKEY20
17	Fuse Kit	DUFKNX
18	Strain Relief (ECU)	DH3/4NMCC
19	Alarm	DUAL10
20	6 Conductor Cable, 16 AWG Shielded	VA-CB16

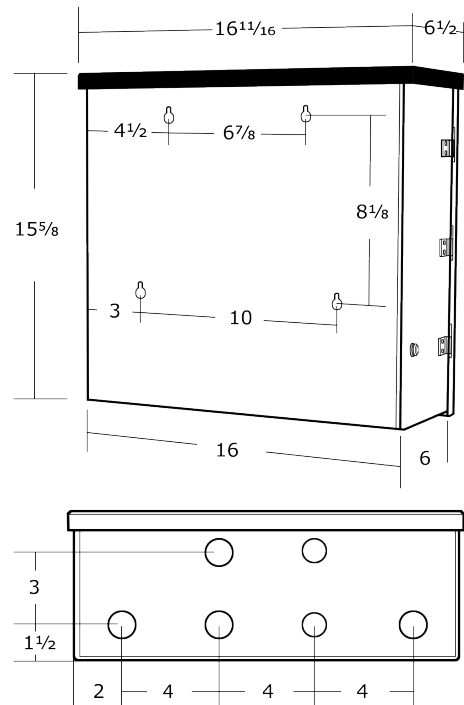

IMPORTANT SAFETY INFORMATION

 **WARNING! Not Following these instructions may cause severe injury or death.**

IMPORTANT SAFETY INSTRUCTIONS

 **WARNING! To reduce the risk of severe injury or death.**

1. READ AND FOLLOW ALL INSTRUCTIONS.
2. Never let children operate or play with gate controls. Keep the remote away from children.
3. Always keep people and objects away from the gate. **NO ONE SHOULD CROSS THE PATH OF THE MOVING GATE.**
4. Test the gate operator monthly. The gate **MUST** reverse on contact with a rigid object or when an object activates the non-contact sensors. After adjusting the force or the limit travel, retest the gate operator. Failure to adjust and retest the gate operator properly can increase the risk of injury or death.
5. Use the emergency release only when the gate is not moving.
6. **KEEP GATES PROPERLY MAINTAINED.** Read the user's manual. Have a qualified service person make repairs to gate hardware.
7. The entrance is for vehicles only. Pedestrians must use a separate entrance.
8. **Every gate operator installation MUST have secondary protection devices against entrapment, such as edge sensors and photo beams more in particularly in places where the risk of entrapment is more likely to occur.**
9. SAVE THESE INSTRUCTIONS.

IMPORTANT INSTALLATION INSTRUCTIONS

1. Install the gate operator only when:
 - a. The operator is appropriate for the construction of the gate and usage Class of the gate (refer to page 9),
 - b. All openings of a horizontal slide gate are guarded or screened from the bottom of the gate to a minimum of 6 feet (1.83 m) above the ground to prevent a 2-1/4 inch (57.2 mm) diameter sphere from passing through the openings anywhere in the gate, and in that portion of the adjacent fence that the gate covers in the open position,
 - c. **ALL EXPOSED PINCH POINTS ARE ELIMINATED OR GUARDED, AND**
 - d. **GUARDING IS SUPPLIED FOR EXPOSED ROLLERS.**
2. The Operator is intended for installation only on gates used for vehicles. Pedestrians must be supplied with a separate access opening. The pedestrian access opening shall be designed to promote pedestrian usage. Locate the gate such that persons will not come into contact with the vehicular gate during the entire path of travel of the vehicular gate.
3. The gate must be installed in a location so that enough clearance is supplied between the gate and adjacent structures when opening and closing to reduce the risk of entrapment. Swinging gates shall not open in to the public access areas.
4. The gate must be properly installed and work freely in both directions prior to the installation of the gate operator. Do not over-tighten the operator clutch or pressure relief valve to compensate for a damaged gate.
5. The gate operator controls must be placed so that the user has full view of the gate area when the gate is moving **AND AWAY FROM THE GATE PATH PERIMETER.**
6. Controls intended for user activation must be located at least six feet (6') away from any moving part of the gate and where the user is prevented from reaching over, under, around or through the gate to operate the controls.

Exception: Emergency access controls only accessible by authorized personnel (i.e. fire, police, EMS) may be placed at any location in the line-of-sight of the gate.

IMPORTANT SAFETY INFORMATION

⚠ WARNING! Not Following these instructions may cause severe injury or death.

IMPORTANT INSTALLATION INSTRUCTIONS (Continued)

7. The Stop and/or Reset button must be located in the line-of-sight of the gate. Activation of the reset control shall not cause the operator to start.
8. A minimum of two (2) WARNING SIGNS shall be installed, in the area of the gate. Each placard is to be visible by persons located on the side of the gate on which the placard is installed.
- 9. For gate operators using non-contact sensors (photoelectric beam or like) in accordance with section 32.1.1 of the UL standard:**
 - a. See instructions on the placement of non-contact sensors for each type of application (refer to page 10).
 - b. Care shall be exercised to reduce the risk of nuisance tripping, such as when a vehicle, trips the sensor while the gate is still moving, and
 - c. One or more non-contact sensors shall be located where the risk of entrapment or obstruction exists, such as the perimeter reachable by a moving gate or barrier (refer to page 10).
 - d. For UL compliance: Use Viking: FA-XP30-10K // Omron: E3K-R10K4-NR-1 // EMX: IRB-RET, IRB-MON // Miller Edge: RG-K-R, PG-K-R100, PG-K-R50, MIM-62 // Seco-Larm E-931-33PRGQ, E-936-S45RRGQ, E-931-S50RRGQ, E-960-D90GQ // EMX NIR-50-325
- 10. For a gate operator utilizing a contact sensor (edge sensor or like) in accordance with section 32.1.1 of the UL 325 standard:**
 - a. One or more contact sensors shall be located where the risk of entrapment or obstruction exists, such as a the leading edge, trailing edge, and post mounted both inside and outside of a vehicular horizontal slide gate (refer to page 10).
 - b. One or more contact sensors shall be located at the bottom of a vehicular vertical lift gate.
 - c. One or more contact sensors shall be located at the pinch point of a vehicular vertical pivot gate.
 - d. A hardwired contact sensor shall be located and its wiring arranged so that the communication between the sensor and the gate operator is not subject to mechanical damage.
 - e. A wireless contact sensor such as one that transmits radio frequency (RF) signals to the gate operator for entrapment protection functions shall be located where the transmission of the signals are not obstructed or impeded by building structures, natural landscaping or similar obstructions. A wireless contact sensor shall function under the intended end-use conditions.
 - f. One or more contact sensors shall be located on the inside and outside leading edge of a swing gate. Additionally, if the bottom edge of a swing gate is greater than 6 inches (152 mm) but less than 16 inches (406 mm) above the ground at any point in its arc of travel, one or more contact sensors shall be located on the bottom edge.
 - g. One or more contact sensors shall be located at the bottom edge of a vertical barrier (arm).
 - h. For UL compliance: Use only EMX: WEL-200K // Miller Edge: ME110 through ME117, ME120, ME123, MGO20, MGR20, MGS20, RB-G-K10, MIM-62 // ASO: 25.30, 25.45, 95.20

IMPORTANT SAFETY INFORMATION

 **WARNING! Not Following these instructions may cause severe injury or death.**

MAINTENANCE

Remove the Power Harness from the Control Board. (refer to page 20)

- Clean and lubricate the turning pins and gate hinges using the recommended lubricant.
- Check that all mounting hardware of the gate operator is properly tighten.
- Ensure that the gate moves freely.
- Check for corroded parts and replace if necessary.
- Check the battery for the following:
 - Battery connections must be free of corrosion.
 - Battery voltage must be 26VDC (fully charged battery).

Reconnect the Power Harness for the Control Board. (refer to page 20)

- Check and confirm the proper operation of all safety devices (photoelectric eye, edge sensors or like).
- Check and confirm the operation of all installed accessories.
- Check and confirm the operation of all special features such as the Intelligent Obstruction Sensor and Hold Open Timer. (refer to pages 25-27)
- Check and confirm the operation of the manual release. (refer to page 11)
- Verify the functionality of the battery backup, or power failure option, by turning off the main power source (115VAC or 230VAC). **DO NOT FORGET TO TURN ON THE MAIN POWER SOURCE AFTER VERIFICATION.**

GENERAL SAFETY PRECAUTIONS

The following precautions are an integral and essential part of the product and must be supplied to the user. Read them carefully as they contain important indications for the safe installation, use and maintenance.

- These instruction must be kept and forwarded to all possible future users of the system.
- This product must be used only for that which it has been expressly designed.
- Any other use is to be considered improper and therefore dangerous.
- The manufacturer cannot be held responsible for possible damage caused by improper, erroneous or unreasonable use.
- Avoid operating in the proximity of the hinges or moving mechanical parts.
- Do not enter the path of the moving gate while in motion.
- Do not obstruct the motion of the gate as this may cause a situation of danger.
- Do not allow children to play or stay within the path of the moving gate.
- Keep remote control or any other control devices out of the reach of children, in order to avoid possible involuntary activation of the gate operator.
- In case of break down or malfunctioning of the product, disconnect from the main power source. Do not attempt to repair or intervene directly, contact only qualified personnel for repair.
- Failure to comply with the above may create a situation of danger.
- All cleaning, maintenance or repair work must be carried out by qualified personnel.
- In order to guarantee that the system works efficiently and correctly it is important to have the manufacturer's instructions on maintenance of the gate and operator carried out by qualified personnel.
- In particular, regular checks are recommended in order to verify that the safety devices are operating correctly.

All installation, maintenance and repair work must be documented and made available to the user.

IMPORTANT SAFETY INFORMATION

CAUTION: To Reduce the Risk of Fire or Injury to Persons:

- a. Use only the following type and size battery(ies): Yuasa NP7-12 or VIKING DUBA12
- b. Do not dispose of the battery(ies) in fire. The cells may explode. Check with local codes for possible disposal instructions.
- c. Do not open or mutilate the battery(ies). Released electrolyte is corrosive and may cause damage to the eyes or skin. It may be toxic if swallowed.
- d. Exercise care in handling batteries in order not to short the battery with conducting materials such as rings, bracelets and keys.
- e. Change the battery(ies) provided with or identified for use with this product only in accordance with the instructions and limitations specified in this manual.
- f. Observe proper polarity orientation between the battery(ies) and charging circuit.
- g. Do not mix batteries of different sizes or from different manufactures in this product (applies to products employing more than one user replaceable secondary battery).
- h. A battery-operated product employing a secondary battery supply intended to be charged within the product shall contain specific instructions concerning the proper method of charging.

UL325 Gate Operator Classifications

GLOSSARY

RESIDENTIAL VEHICULAR GATE OPERATOR

CLASS I - A vehicular gate operator (or system) intended for use in garages or parking areas associated with a residence of one-to four single families.

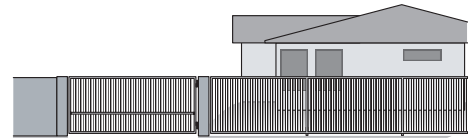

COMMERCIAL/GENERAL ACCESS VEHICULAR GATE OPERATOR

CLASS II - A vehicular gate operator (or system) intended for use in a commercial location or building such as a multi-family housing unit (five or more single family units), hotel, garages, retail store, or other building servicing the general public.

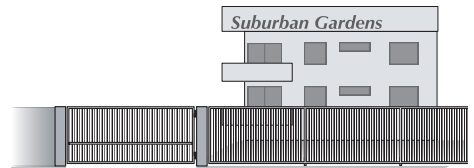

INDUSTRIAL/LIMITED ACCESS VEHICULAR GATE OPERATOR

CLASS III - A vehicular gate operator (or system) intended for use in an industrial location or building such as a factory or loading dock area or other locations not accessible by or intended to service the general public.

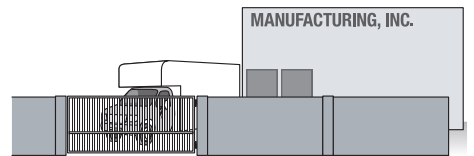

RESTRICTED ACCESS VEHICULAR GATE OPERATOR

CLASS IV - A vehicular gate operator (or system) intended for use in a guarded industrial location or building such as an airport security area or other restricted access locations not servicing the general public, in which unauthorized access is prevented via supervision by security personnel.

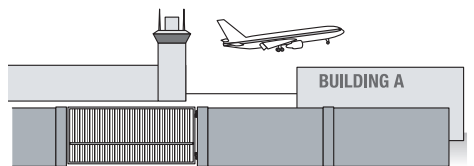

Install the gate operator only when:

The operator is appropriate for the construction of the gate and the Usage Class of the gate.

IMPORTANT SAFETY INFORMATION

⚠ WARNING! Not Following these instructions may cause severe injury or death.

Monitored Entrapment Protection Requirements

IMPORTANT: MONITORED PROTECTION MUST BE INSTALLED

- **REQUIRED BY UL 325, an approved MONITORED entrapment protection sensor is REQUIRED to be installed in all areas accessible to potential entrapment and pinch points.**
- For a horizontal swing gate operator, at least one Monitored External Entrapment Sensor is required in each direction of travel. Except, if there is no entrapment zone in one direction of travel, it is not required to have a Monitored Entrapment sensor for that direction of travel.
 - ⚠ If there is a possible entrapment zone in the open direction, an external sensor MUST be connected to the “UL” input or the installation will not comply with UL 325.
 - ⚠ An external sensor connected to the “Re-Open” input terminal will protect against entrapment ONLY in the closing direction.
- The installed sensor MUST be **“10K Resistor Based”**.
- You may connect up to FOUR monitored sensors, wired in parallel, to either the “UL” and/or “Re-Open” terminals, for a total of 8 monitored sensors.
- **Failure to install the required monitored entrapment protection sensor(s) may render the gate operator INOPERABLE. The gate can be moved manually. Refer to page 11.**
- Consult the installation manual of the sensor for detailed information about the usage, installation and maintenance.
- Use only UL Recognized Component Edge Sensors and Photoelectric Sensors. Refer to pg 7.

SWING GATE ENTRAPMENT ZONE – Locations between a moving gate or moving, exposed operator components and a counter opposing edge or surface where entrapment is possible up to 1.8 m (6 ft) above grade. Such locations occur if during any point in travel:

- a. The gap between the bottom of a moving gate and the ground is greater than 101.6 mm (4 in) and less than 406 mm (16 in); or
- b. The distance between the center line of the pivot and the end of the wall, pillar, or column to which it is mounted when in the open or closed position exceeds 101.6 mm (4 in). Any other gap between a moving gate and fixed counter opposing edges or surfaces or other fixed objects is less than 406 mm (16 in) (examples are walls, curbs, berms or other immovable objects).

Photoelectric Sensor (non-contact sensor)

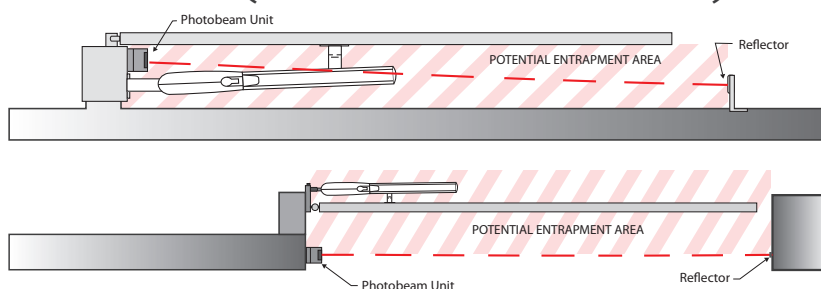

Edge Sensor (contact sensor)

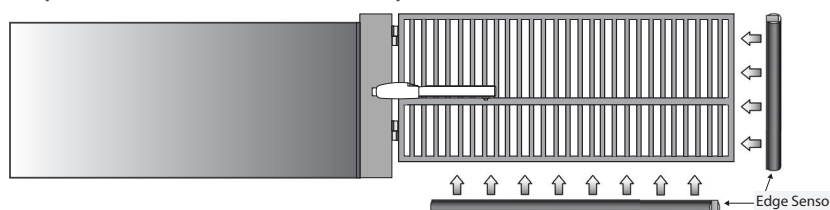

IMPORTANT SAFETY INFORMATION

⚠ WARNING! Not Following these instructions may cause severe injury or death.

Monitored Entrapment Protection Installation

⚠ IMPORTANT: A minimum of one Monitored External Entrapment Sensor is required to be connected to the UL terminal OR the Re-Open terminal. If there is a possible entrapment zone in the open direction, an external sensor **MUST** be wired to the “UL” input or the installation will not comply with UL 325.

“UL” Protects against entrapment in both the opening and closing directions. Input will reverse the gate momentarily in the opposite direction it was traveling. Refer to page 29.

“Re-Open” Protects against entrapment in the closing direction **ONLY**. Input will reverse the gate all the way to the Open Limit. Refer to page 29.

STEP 1: Connect the monitored entrapment protection sensor(s) to the Viking control board as illustrated.

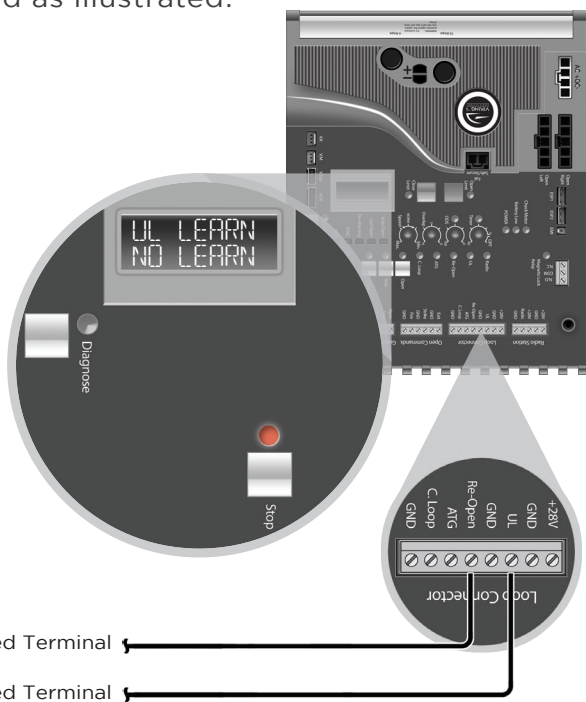

STEP 2:

Execute the Learn Process:

- Toggle the “Diagnose” button until you see UL LEARN NO LEARN on the LCD Display.
- Press and hold the “Stop” button.
- Toggle the “Diagnose” button once.
- The number of Monitored sensors connected to the “UL” or Re-Open terminals will now be displayed.

EXAMPLE: UL LEARN
UL2 RO1

UL SENSOR ERRORS:

If an problem occurs with one of the monitored entrapment sensors, the “Stop” LED will flash and an ERR message will be displayed, indicating which input terminal(s) the sensor is connected to.

TERMINAL:	“UL”	“Re-Open”	“UL” & “Re-Open”
ERROR MESSAGE:	ERR SENS UL	ERR SENS RO	ERR SENS UL RO

Manual Release

When manual operation is required:

- Open the cover to the Lock
- Inset the Release Key into the Lock and rotate towards the gate post.
- Pull the Lever out and manually move the gate.

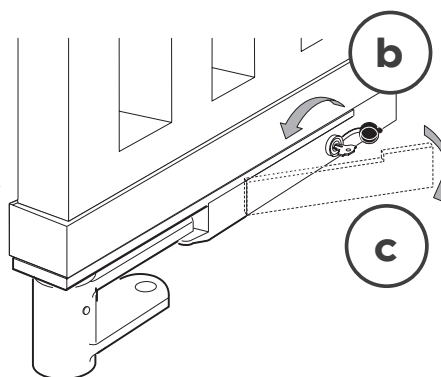

Manual Release

To reengage the gate:

Close the Lever back and rotate the Release Key away from the gate post.

Manually move the gate towards the Manual Release Assembly until engaged.

IMPORTANT SAFETY INFORMATION

⚠ WARNING! Not Following these instructions may cause severe injury or death.

Audible Alarm Reset Switch Installation

Manual Reset for the Audible Alarm

- UL325 standard requires an audible alarm to sound after two consecutive events detected by the inherent entrapment protection of the gate operator (obstruction sensor).
- The audible alarm will continue to sound for 5 minutes or until a stop command is actuated.
- The Stop command can be actuated in three different forms:
 1. Using the Built in Stop switch on the Control Board; or
 2. Using an External Stop button within the sight of the gate, away from moving parts of the gate and out of reach of children.
 - a. Controls intended for user activation must be located at least six feet (6') away from any moving part of the gate and where the user is prevented from reaching over, under, around, or through the gate to operate the controls. Outdoor or easily accessible controls shall have a security feature to prevent unauthorized use.
 - b. The Stop and/or Reset button must be located in the line-of-sight of the gate. Activation of the reset control shall not cause the operator to start.
 3. Using the Reset Button on the Electronic Control Unit that is externally accessible on the left side of the cabinet.

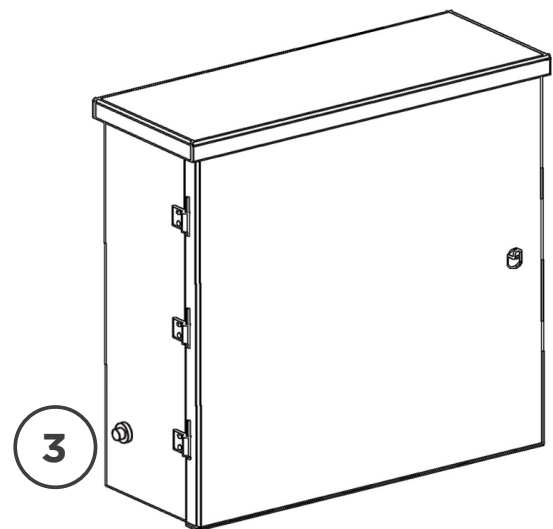
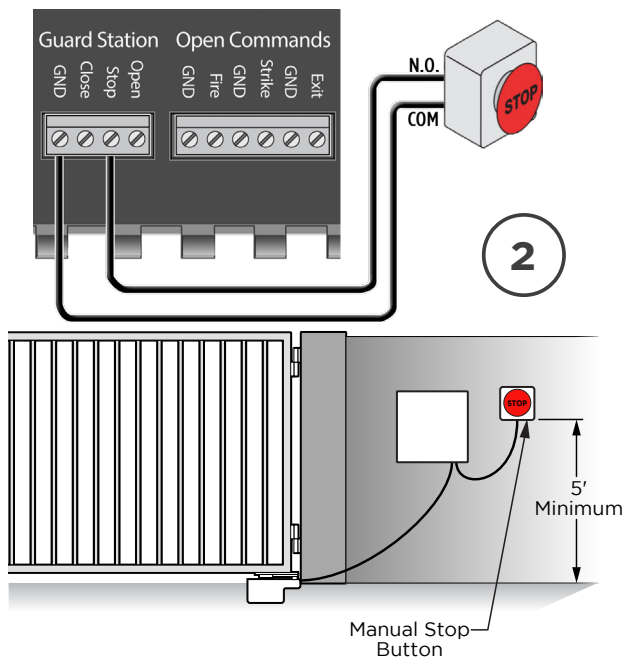

Warning Placard Installation

- All Warning Placards must be installed where visible in the area of the gate.
- A minimum of two placards shall be installed.
- A placard is to be installed in the area of each side of the gate and be visible.

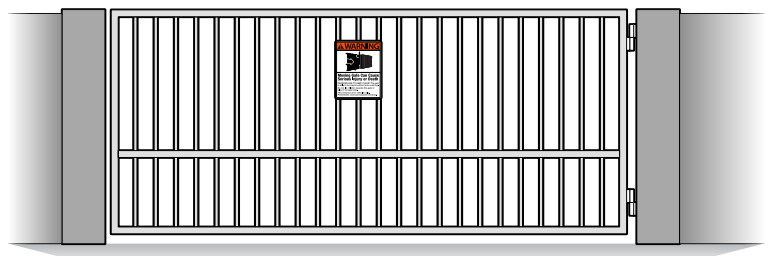

IMPORTANT INSTALLATION INFORMATION

⚠ CAUTION: To Reduce the Risk of Fire or Injury to Persons:

⚠ WARNING: For use with gates at a maximum 650 lbs. in weight or 12 ft. in length.



DO NOT allow pedestrian use of this gate

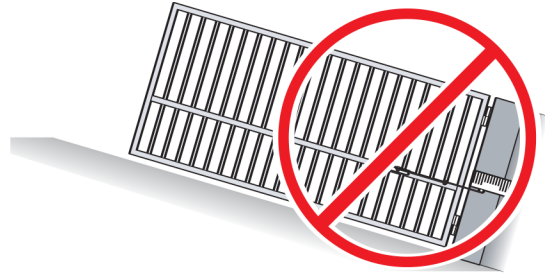

DO NOT install the gate operator to lift gates

Locate Control Buttons:

1. Within sight of the gate,
2. At a minimum height of 5 feet so small children are not able to reach it; and
3. At least 6 feet away from all moving parts of the gate.

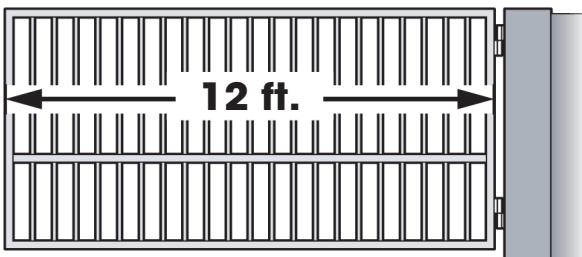
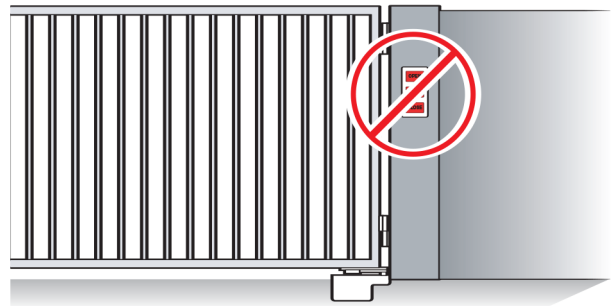

Specifications:

UL 325 Classification:

Class I, II, III, IV *Refer to page 9

Power Requirements:

120VAC / 240VAC (1.5* Amp / 1.0* Amp) *Each Gate Operator
Single Phase (50Hz / 60Hz)

Alternative Power

24VAC / VDC (60VA) or Solar

Operating Temperature:

-20°F (-28°C) to 131°F (55°C)

Maximum Gate Length:

12 ft.

Maximum Gate Weight:

650 lb.

GATE OPERATOR INSTALLATION

Plans of Installation

The gate must be installed in a location so that enough clearance is provided between the gate and adjacent structures to reduce the risk of entrapment when opening and closing. Swing gates are not to open into public access areas.

STEP 1

Top Gate Hinge:

Ensure the center of the Top Hinge is 2.50" from the mounting surface.

⚠ **TIP:** If the hinge center is less than 2.50" from the surface, clearance will have to be cut into the lower mounting surface to allow the center of the articulation point to align to the hinge used.

STEP 2

Prepare for in-ground installation:

- Use a Plumb Bob and mark a center reference for the Articulation Point of the Gate Operator.
- Mark the surface area to be worked.
- Prepare the surface area for the Gate Operator. Ensure the operator will sit level and that the Articulation Point will be aligned with the Upper Hinge.

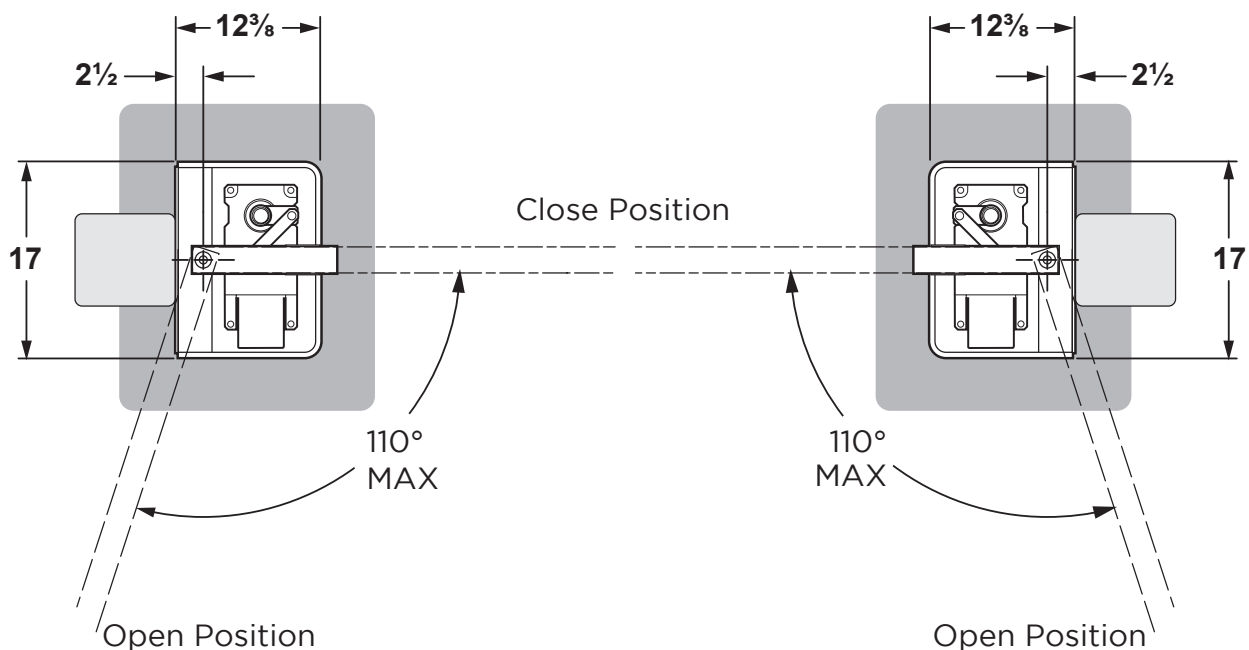
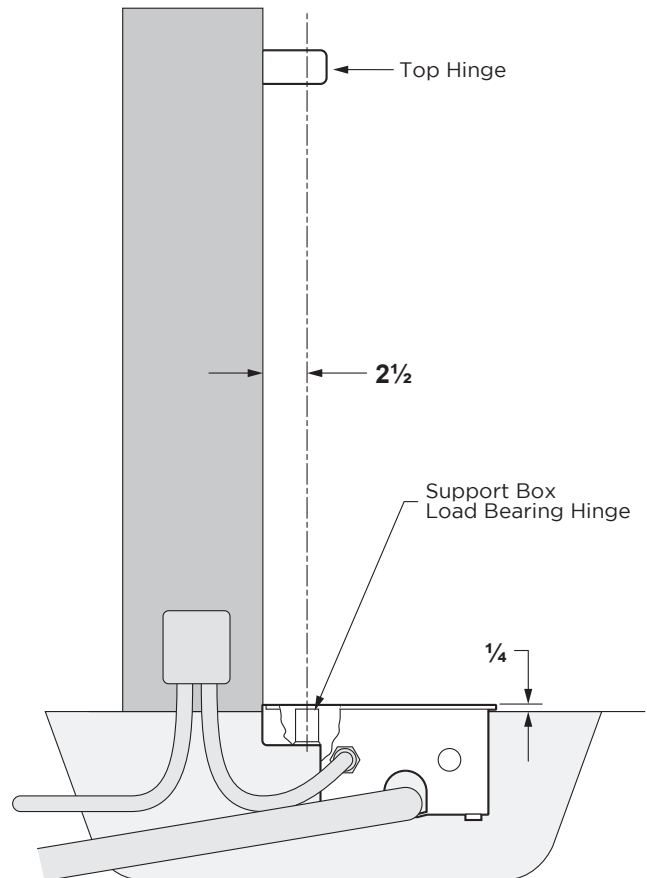

GATE OPERATOR INSTALLATION

Plans of Installation

STEP 3

Prepare for Wiring:

Install conduit suited for the application. Route the conduit to an above ground junction box.

STEP 4

Prepare for drainage:

Run a flexible drain pipe from the Gate Operator to an area drain. Ensure a proper slope and adequate drainage to prevent any water accumulation within the motor area.

STEP 5

Instal the Chassis:

- Ensure the Chassis is level in both directions and that the Articulation Point is properly aligned.

⚠ IMPORTANT:

- USE A LEVEL
 - USE A PLUMB BOB
 - CHECK TWICE to ensure proper alignment.
- Fill the area with concrete and level off approximately 0.25" below the top of the Chassis. Before the concrete is fully cured, check for level and alignment again.

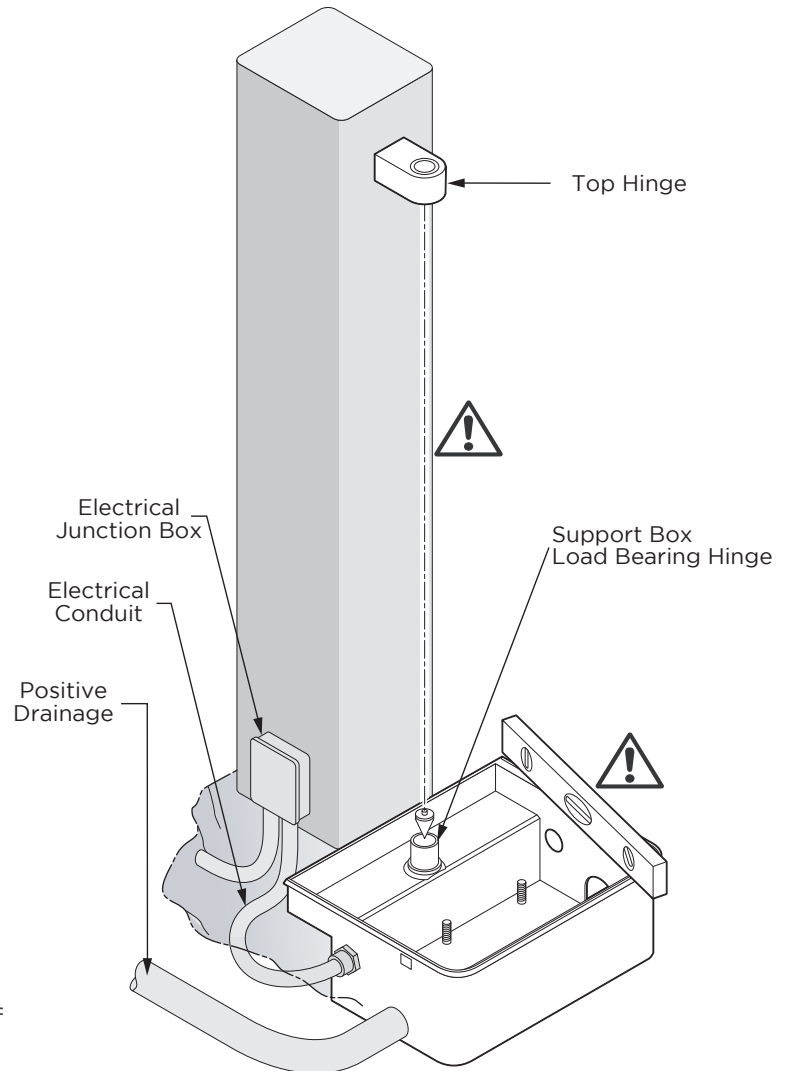

GATE OPERATOR INSTALLATION

Installing the Gate Operator

STEP 1

Install the Motor/Gear Assembly:

Position the Motor/Gear Assembly in the Support Box according to the opening direction of the Gate

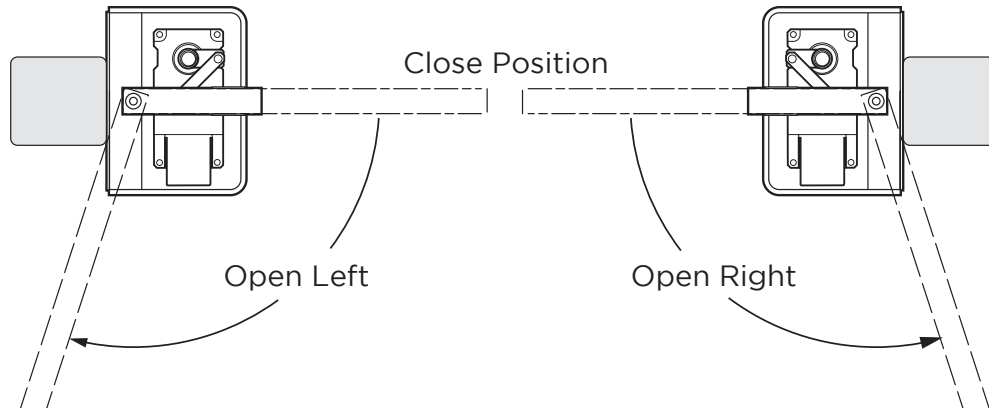

STEP 2

Wire to the Junction Box:

- Route the wires from the Motor/Gear Assembly through the conduit and up to the Junction Box.
- Connect the two wires to the wires coming from the Control Board.

STEP 3

Install the Support Bracket:

- Lubricate the Ball Bearing with silicone-based grease and place it onto the pivot point of the Support Box.
- Install the Support Bracket over the Ball Bearing and pivot point of the Support Box.

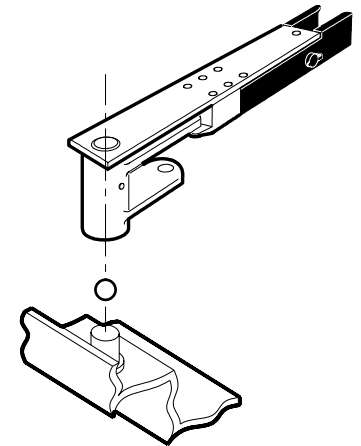

STEP 4

Prepare a Gate Guide: Not Provided

- Select the appropriate "U"-Channel profile steel to use as a Gate Guide.
- Weld the Guide to the Support Bracket.
- Position the gate into the Gate Guide so that the axis of rotation for the gate is plumb.
- Through-bolt the gate to the Gate Guide. This will allow for a slight amount of tolerance in case the axis of rotation is slightly off centered.

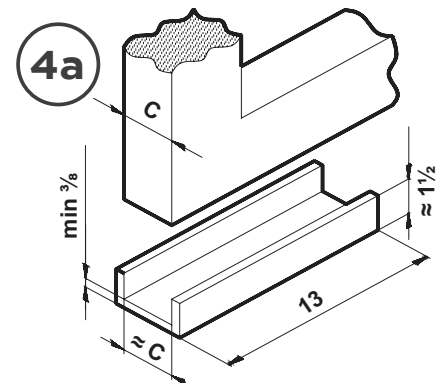

GATE OPERATOR INSTALLATION

Installing the Gate Operator

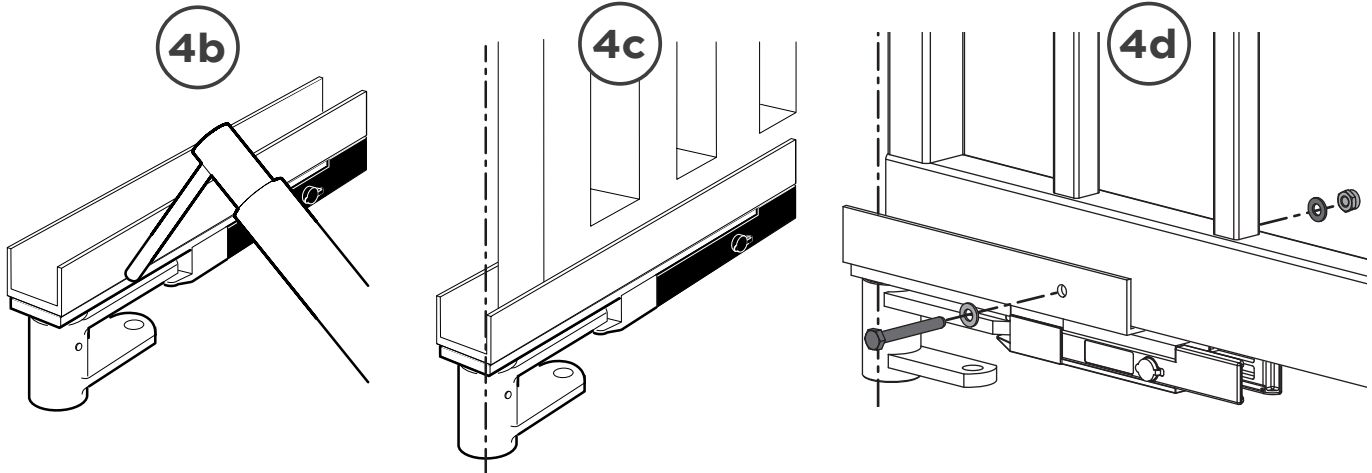

STEP 5

Disengage the Gate:

- Open the cover to the Lock
- Inset the Release Key into the Lock and rotate towards the gate post.
- Pull the Lever out and manually move the gate.

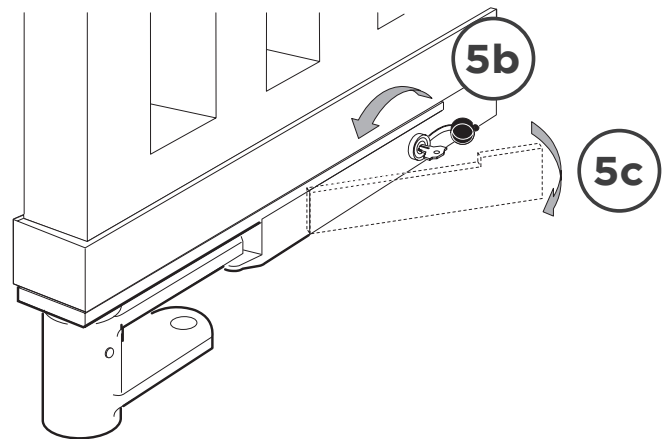

STEP 6

Instal the Articulating Levers:

Manually close the gate and instal the Articulating Levers.

Apply a marine grease to the Output Shaft and all pivoting points.

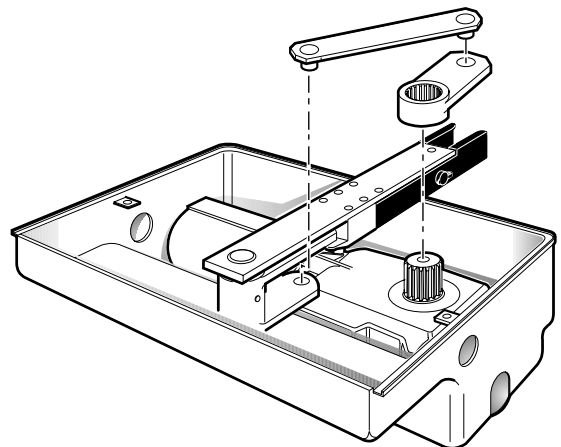

GATE OPERATOR INSTALLATION

Limits Setup

STEP 1

Instal the Positive Stop for the open limit and adjust the open limit position.

STEP 2

Instal the Positive Stop for the close limit and adjust the close limit position.

⚠ IMPORTANT: Each of the Positive Stops are designed for a specific limit position. The Positive Stop locations illustrated below are for Open Left swinging gates. Swap the Positive Stop locations and rotate the Motor/Gear Assembly 180° for Open Right swinging gates.

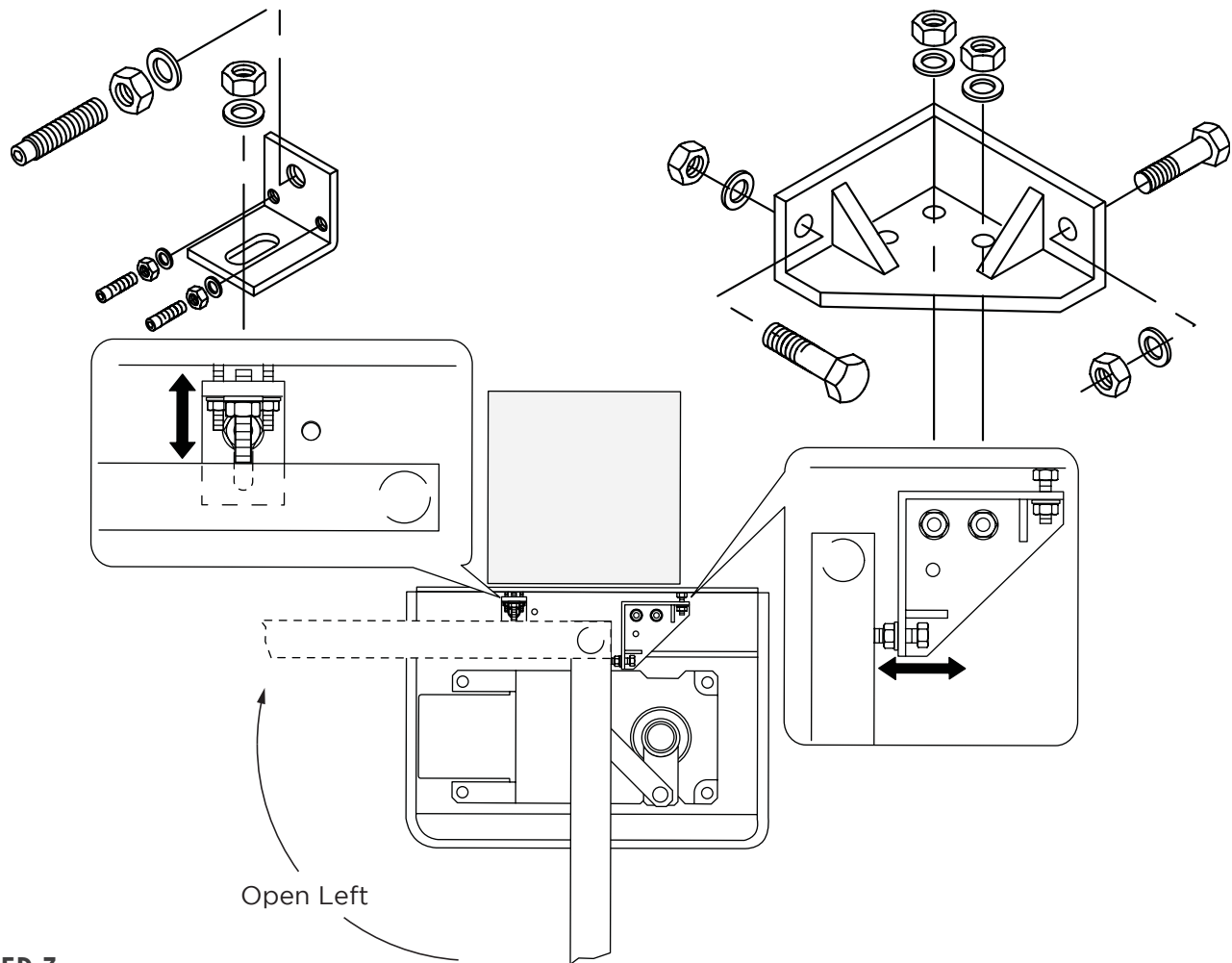

STEP 3

Reengage the gate:

Close the Release Levers and manually move the gate until it reengages with the Release Mechanism.

Lock the Release Levers by rotating the Release Key away from the gate post.

STEP 4

Learn the Limit positions:

Allow the gate operator to run a full open and close cycle (from stop to stop) without interruption so that the operator will learn when to slow down before reaching the limits, providing controlled operation.

ECU BOX INSTALLATION

Mounting the ECU Box

⚠ WARNING: If the control box is not mounted properly it may fall, causing damage and/or injury. The Electronic Control Unit (ECU) weight is approximately 40 lbs. Be sure that the substrate being mounted to and the fasteners being used are appropriate to support the weight of the control box.

STEP 1

Disconnect the Siren, Stop Button and EMI Harness from the Control Board. Remove the Control Board Mounting Plate. The plate is held in the box by four screws.

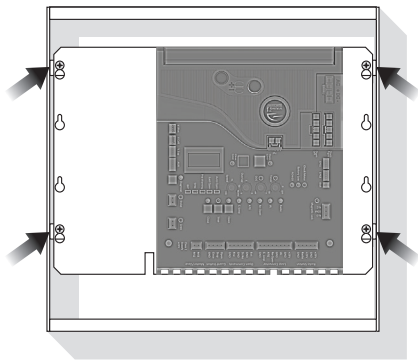

STEP 2

Position the ECU Box in the desired place and mark the mounting holes. Prepare the holes to receive the anchors/fasteners. NOTE: Anchors are Not Supplied.

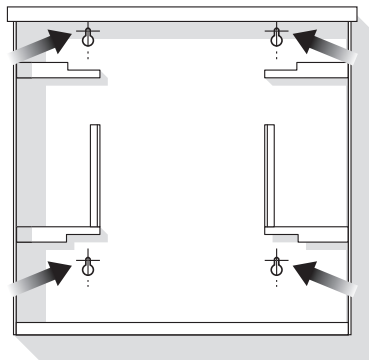

STEP 3

Position the ECU Box and secure it to the mounting surface using the Sealed Washers provided (rubber side of the washers against the inside of the control box).

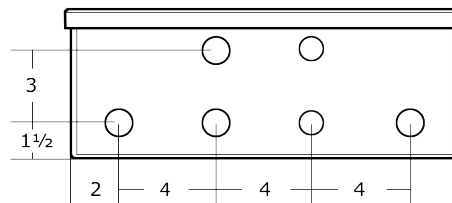
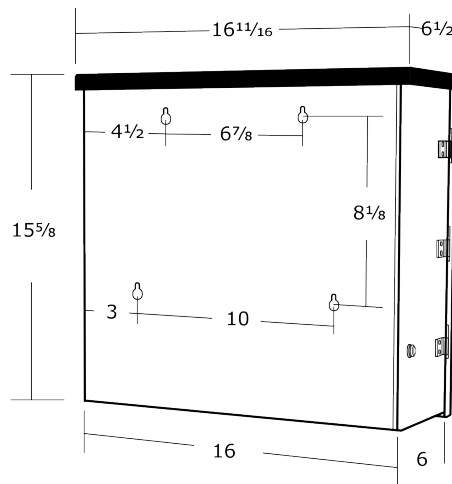
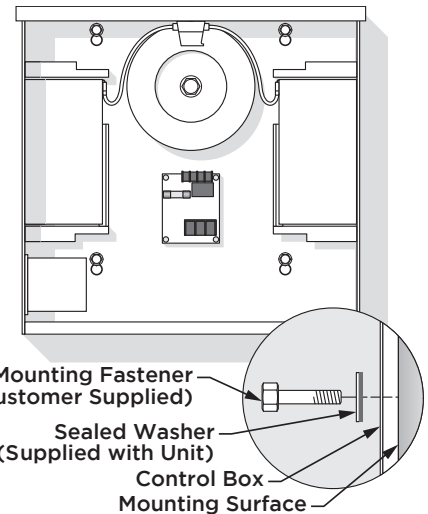

ELECTRICAL INSTALLATION

High Voltage Supply Option

⚠ Caution: Always turn off power breakers when working with high voltage. DO NOT connect the “Power Harness” to the Control Board until the electrical installation is complete and ready for verification.

STEP 1

⚠ WARNING: SINGLE PHASE AC ONLY

At the “EMI Board”:

- Set the “Voltage Selector” according to the supply voltage (115V or 230V).
- Connect the incoming power wires to the terminals as shown in the illustration.
- Ground the ECU cabinet according to local code or guidelines.
- Turn on the main facility breaker and verify that all three (3) Status LEDs are illuminated on the EMI Board.

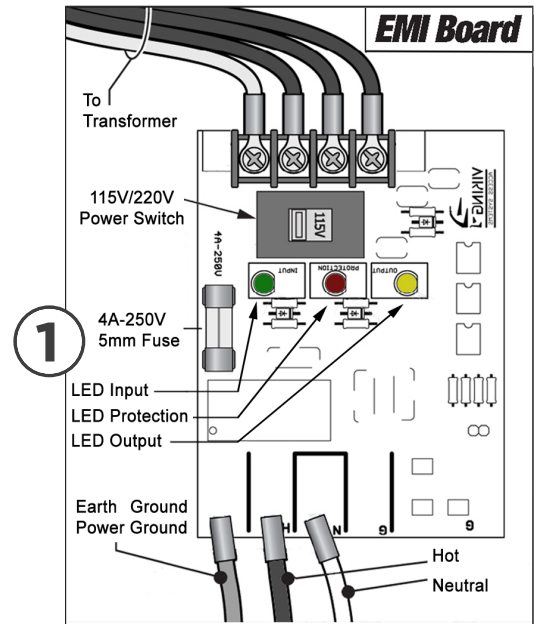

Tips for proper ground installation:

To minimize the effects caused by lightning, follow these guidelines:

- Use a ground rod to provide a ground reference.
- Consult your city code and be aware of underground services in the site of the gate operator to prevent inconveniences.
- Always use a single bonding point for grounding.
- All ground wires must be as short and as thick as possible.
- Prevent unnecessary turns or loops in all ground wires.

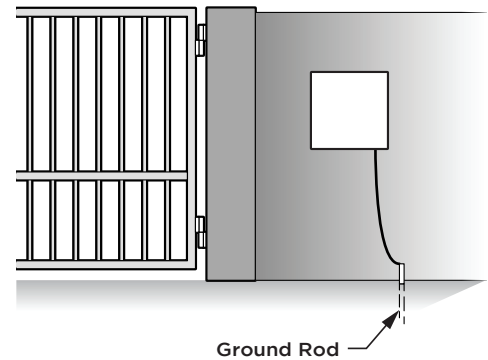

STEP 2

At the Control Board:

- Reinstall the Control Board Mounting Plate with the control board(s).
- Connect the Power Harness and verify the “POWER” LED is illuminated solid.
- Reconnect the EMI Harness.
- Reconnect the Stop Button Harness
- Reconnect the Siren Harness

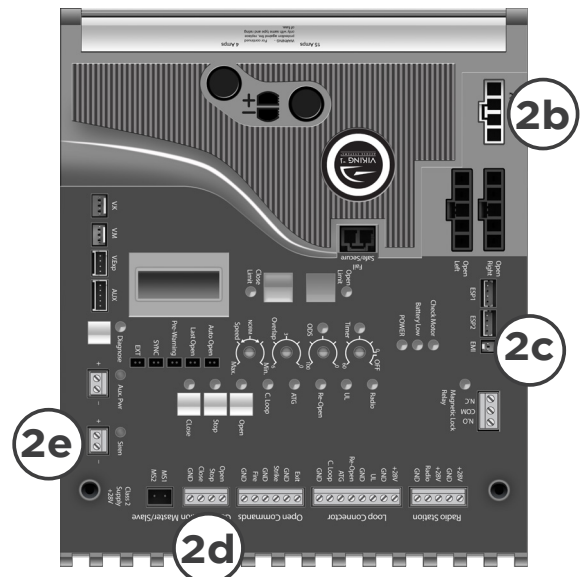

ELECTRICAL INSTALLATION

Low Voltage Supply Option

TIP: As an alternative to high voltage, the operator can be powered by 24VAC. It is recommended to use Vikings Modular Power Box (**part # VNXMPB**) as the source.

⚠ Caution: Always turn off power breakers when working with high voltage. **DO NOT** connect the “Power Harness” to the Control Board until the electrical installation is complete and ready for verification.

Install the “Modular Power Box” at the nearest high voltage source (115V or 230V single phase) and connect to the controller’s Power Harness. Follow local codes or guidelines.

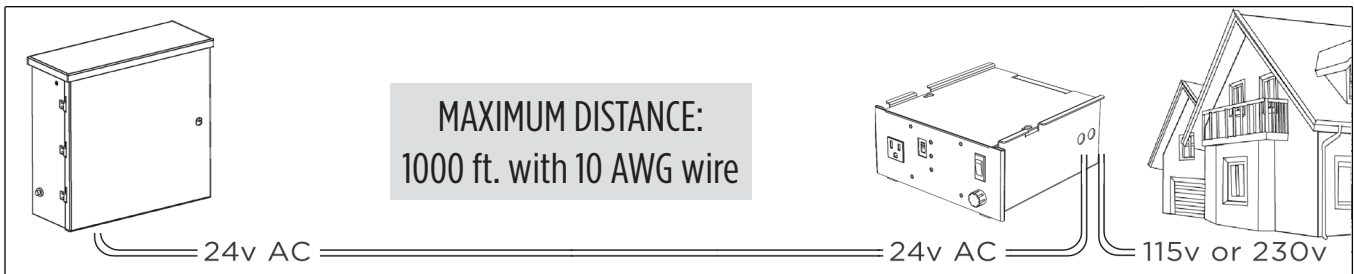

Solar Supply Option

Vikings Solar Package (**part # VA-SOCHP**) is an efficient and effective solution to powering the operator with solar energy. (Page 48 for package details)

⚠ IMPORTANT: See Appendix C

1. Turn ON “SOLAR MODE” from the LCD Display. (Page 45)
2. Use the “Aux. Pwr” terminals to provide power for all safety devices used for Center, Re-Open and UL inputs.

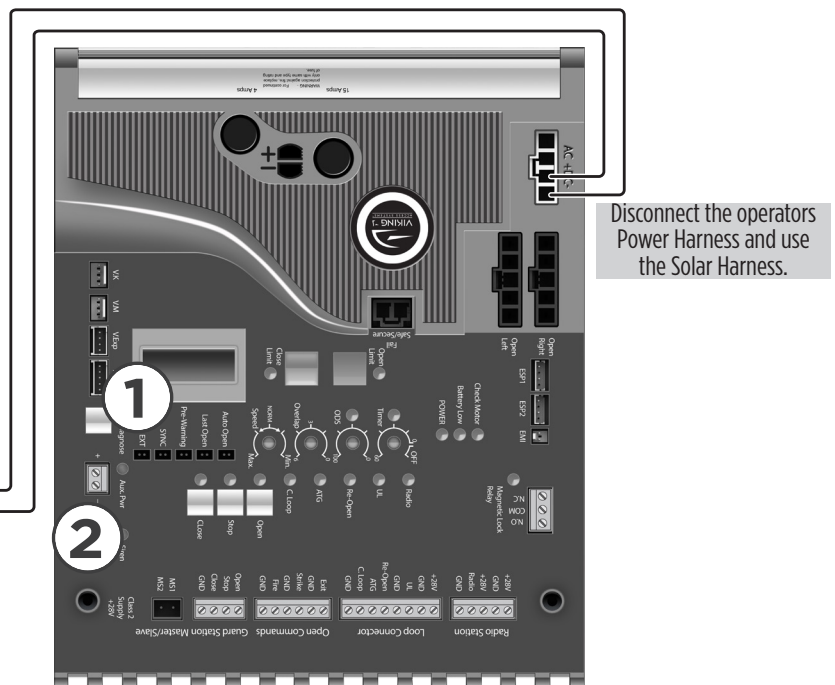
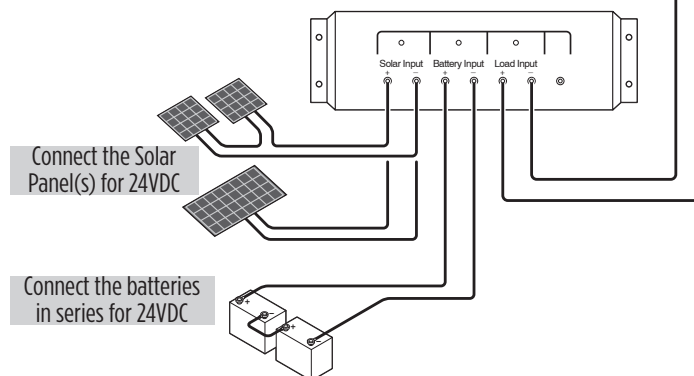

⚠ The number of cycles achieved daily is dependent on many factors, including local solar radiation data and power consumption of the motor and accessories. It is very important that you consider this when using solar power.

ELECTRICAL INSTALLATION

Motor Cable - Primary (Single)

NOTE: The Single Electronic Control Unit is equipped to operate a single gate motor only, and does not include a Secondary Module. The steps described on page 23 do not apply for this type of application.

STEP 3

Primary Motor:

a. Connect the BROWN and BLUE wires from the motor cable to the Motor Connector at the Primary Control Board.

Tip: The jumper wire between terminals 3 & 4 will inform the control board that an I770 operator is connected.

b. Attach the grounding wire, non insulated, to the Board Mounting Plate using the screw provided.

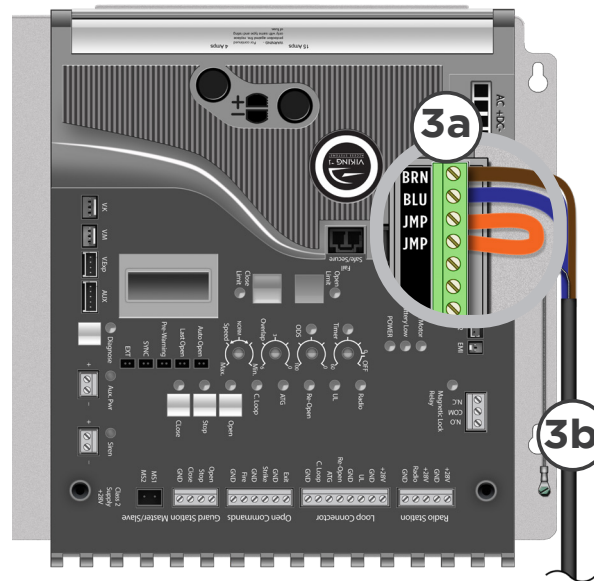

Primary Motor

BROWN

BLUE

JUMPER I-770

JUMPER

NOT USED

NOT USED

NOT USED

STEP 4

Primary Open Left or Open Right:

Place the terminal block in the proper location for the gate opening direction.

- “OPEN RIGHT” Connector if the gate opens **Inside to the Right** or **Outside to the Left**.
- “OPEN LEFT” Connector if the gate opens **Inside to the Left** or **Outside to the Right**.

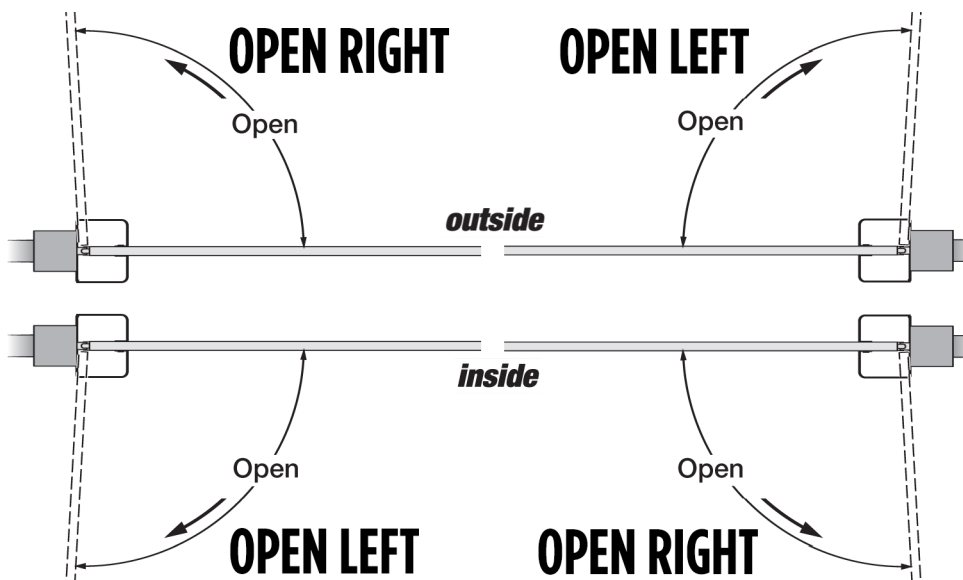

ELECTRICAL INSTALLATION

Motor Cable - Secondary (Dual)

NOTE: The Primary/Secondary, or Dual, Electronic Control Unit is equipped with both the VFlex Control Board (Primary) and a Secondary Module, both are required to operate two gate motors in tandem.

STEP 5

Secondary to Primary Connections:

a. Ensure that the Secondary Power Harness is connected as illustrated. Polarity is important!

Red to “+” Black to “-”

b. Ensure that the Primary/Secondary Communication Cable is connected as illustrated.

STEP 6

Secondary Motor:

a. Connect the BROWN and BLUE wires from the motor cable to the terminal block at the Secondary Module Board.

b. Attach the grounding wire (non insulated) to the Board Mounting Plate using the screw provided.

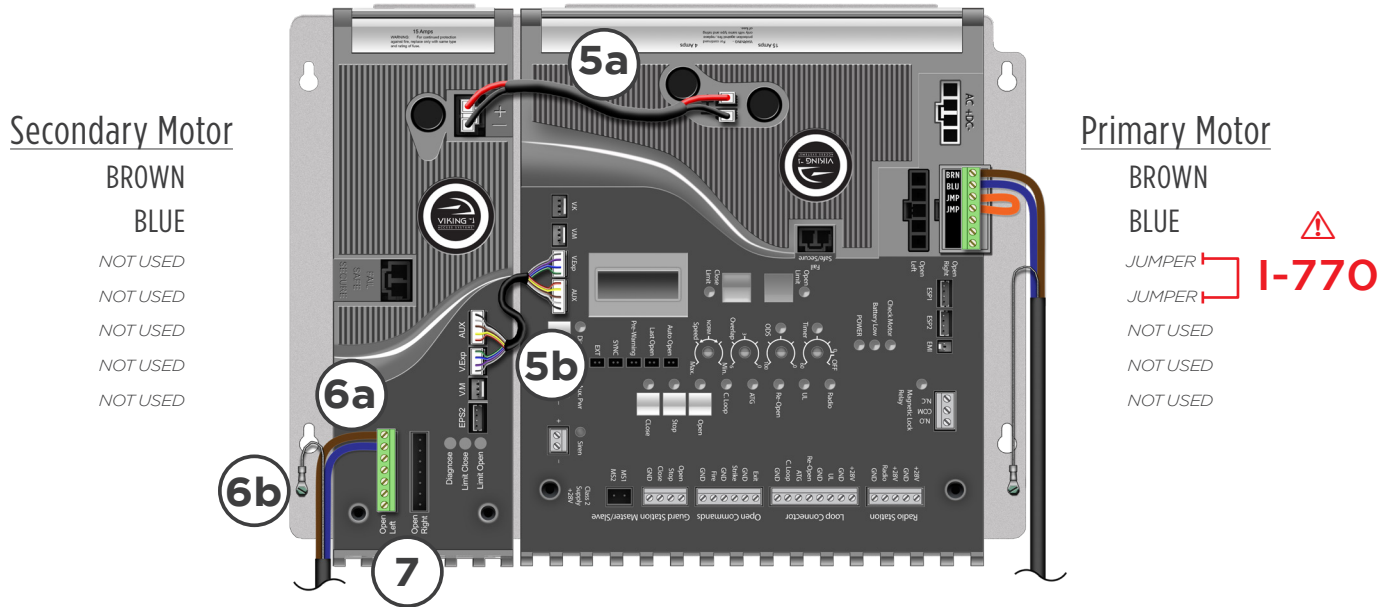

STEP 7

Secondary Open Left or Open Right: Refer to the illustration on page 22.

Place the terminal block in the proper location for the gate opening direction.

- “OPEN RIGHT” Connector if the gate opens **Inside to the Right** or **Outside to the Left**.
- “OPEN LEFT” Connector if the gate opens **Inside to the Left** or **Outside to the Right**.

LIMIT INDICATIONS

⚠ IMPORTANT: The gate operator uses positive stop limits. Therefore, the limits cannot be set electronically by this controller. The Limit Buttons on the control board have been rendered inactive by the controller. Refer to page 18 for specific instructions on how to set the limits for this gate operator..

⚠ TECHNICAL TIP: The Limit LEDs will illuminate solid when this operator reaches its corresponding limit. If both Limit LEDs are illuminated at the same time, this indicates that there is a problem with the limit switches or wiring.

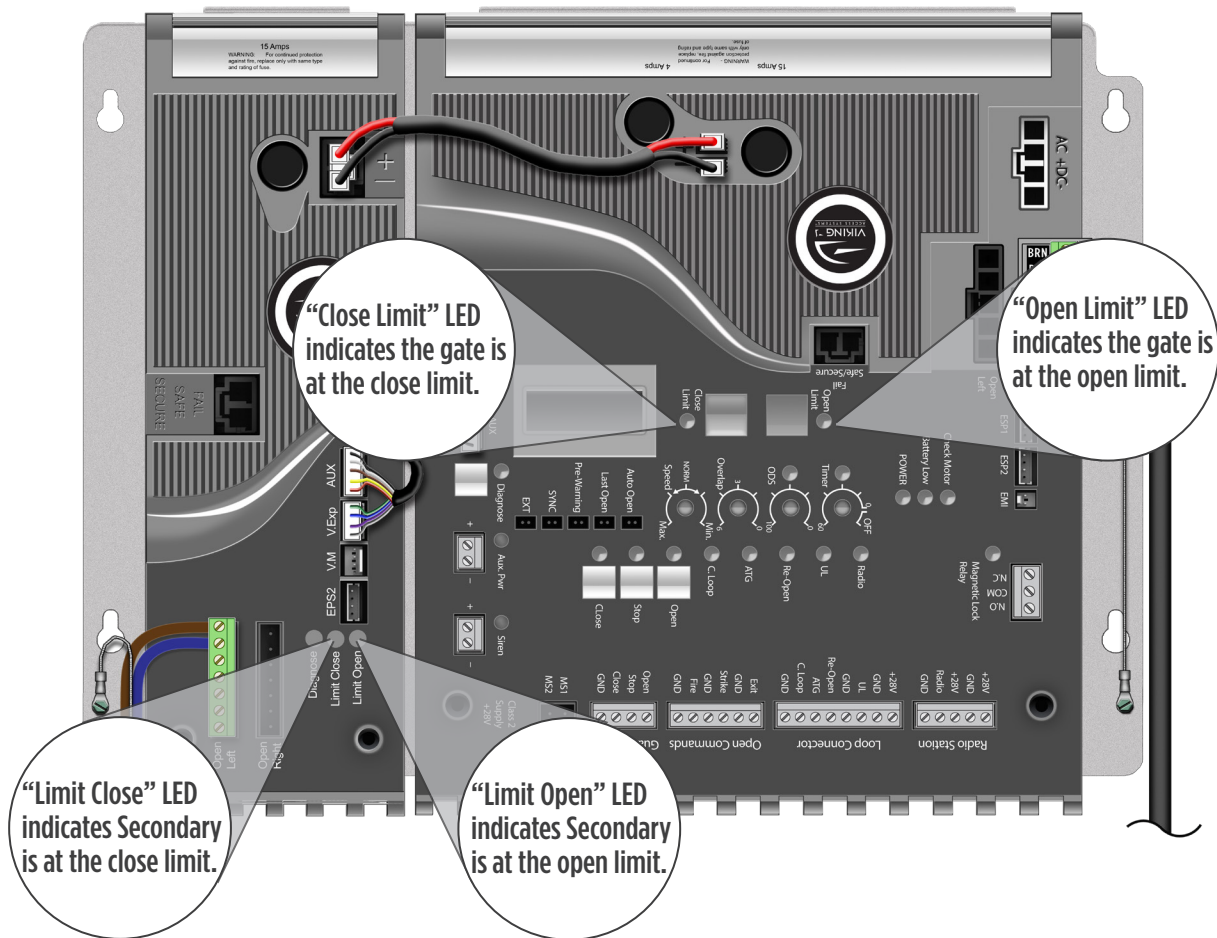

CONTROL BOARD SETUP

Initial Settings

“Speed” Motor Speed

Increases or decreases the speed of gate travel.

“ODS” Obstruction Detection Sensor

Sets the amount of force required to trip the inherent obstruction sensor.

See page 27 for more details about this feature.

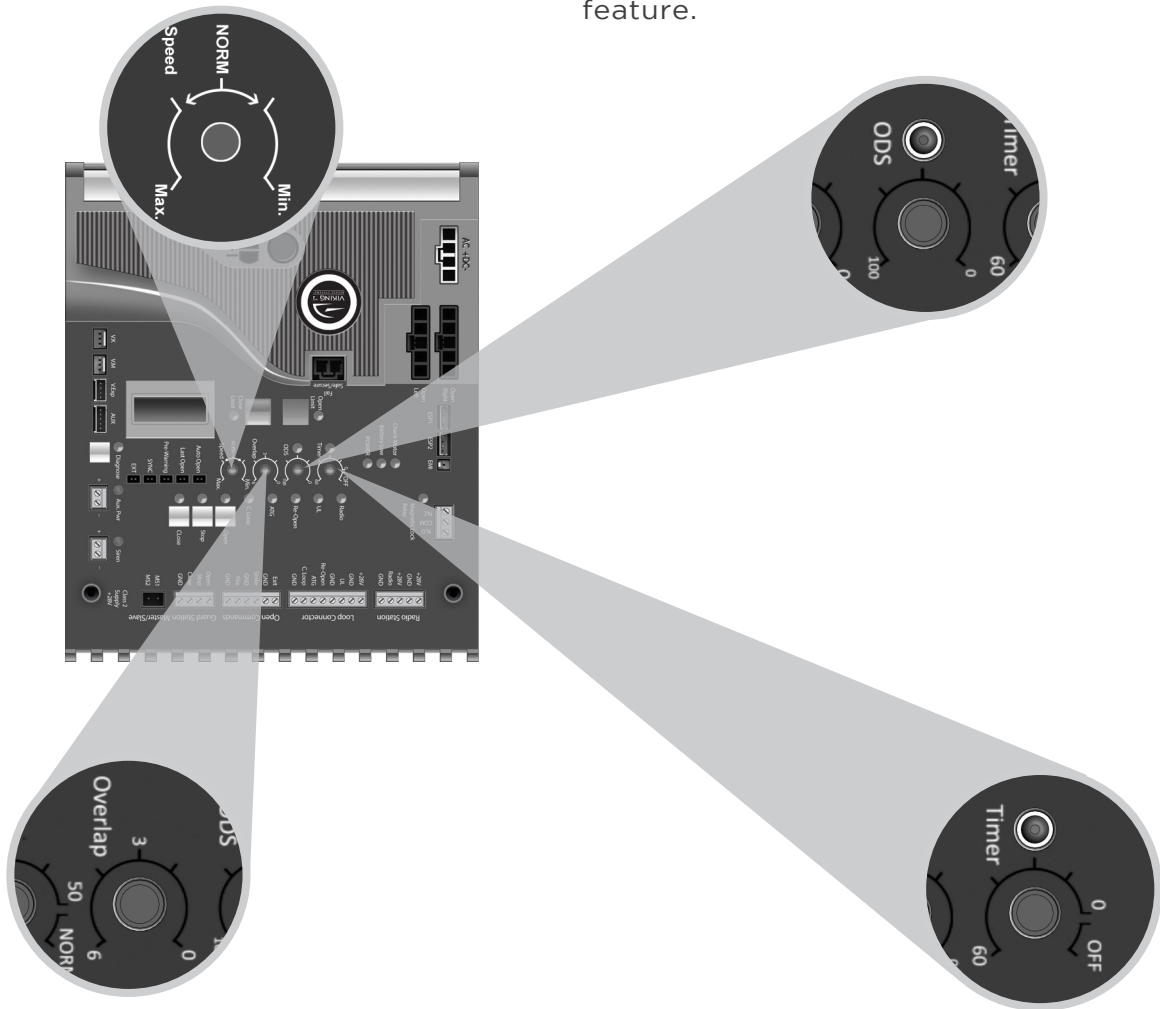

“Overlap” Overlap Delay

Delays the gate from opening for the selected amount of time from 1-6 seconds.

⚠ For Primary/Secondary or dual applications, the Primary will delay to open and the Secondary will delay to close.

“Timer” Hold Open Timer

Automatically closes the gate after the selected amount of time from 1-60 seconds.

Turning the dial between “0” and “OFF” will disable this feature, requiring a close command to close the gate.

CONTROL BOARD SETUP

Initial Settings

NOTE: Installing a shunt, or jumper, on the pins will activate the feature.

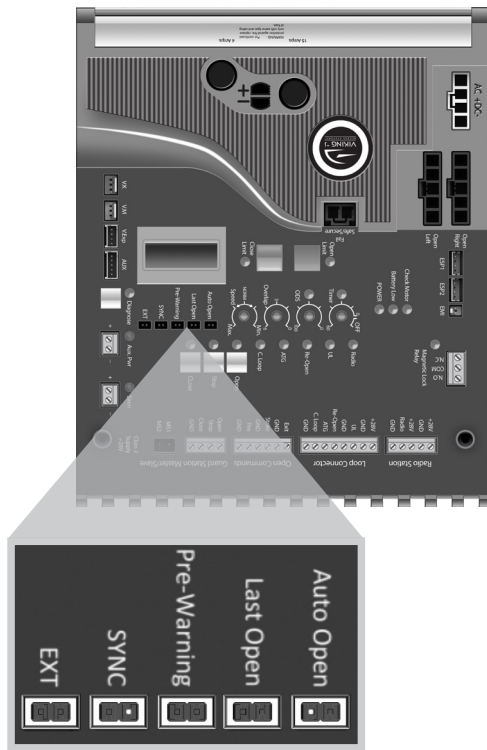

“Auto Open” - Power Failure Option

Opens the gate automatically during power failure. Resumes normal operation when power is restored.

⚠ Disabled when “Solar Mode” is ON.

“Last Open” - Power Failure Option

Opens the gate automatically when the battery backup voltage is critically low.

“Pre-Warning” Initiates two options for an audio or visual warning 3 seconds prior to gate motion and will continue:

1. Until gate reaches closed limit:

“Magnetic Lock” terminals provide a contact between “COM” and “N.O.”.

2. While gate is moving:

“AUX. PWR” terminals provide 24VDC.

“Sync” Used only in conjunction with Barrier Arm Operators. Activating this feature allows for synchronized operation with Barrier Arm Operators. See page 35.

“EXT” Available for future developments.

CONTROL BOARD SETUP

Obstruction Detection Sensor (ODS)

⚠ IMPORTANT: The appropriate “ODS” setting is dependant upon the gate installation and construction. Set this feature accordingly. Additional Safety equipment should be used to reduce possible risk of injury or vehicle damage.

“ODS” Obstruction Detection Sensor

The Obstruction Sensor detects obstructions in the path of the traveling gate. The dial sets the amount of force required to activate the operators inherent obstruction detection.

Setting the dial to “0” will require the least amount of force to activate;

Setting the dial to “100” will require the maximum amount of force to activate.

UL325 standard requires an audio alarm to go off after two consecutive entrapment events sensed by the Inherent Entrapment Protection of the Gate Operator.

The audio alarm will sound for a period of 5 minutes or until a Stop command or the “Alarm Reset” switch has been actuated. (refer to page 12)

When the Obstruction Sensor detects an obstruction it will:

1. Stop the gate’s movement and reverse it momentarily.
2. Bring the gate to a resting position.
3. Disable the Hold Open Timer feature until the Gate Operator receives a new command.

If second obstruction is detected before the gate reaches either limit it will:

1. Stop the gate’s movement.
2. Disable the Gate Operator.
3. Sound the UL Alarm
4. A STOP command must be provided to disable the alarm and continue operation.

⚠ TECHNICAL TIP: The Status LED for the “ODS” will indicate the following when it has been triggered.

- A. Solid:** Obstruction.
Detected a sudden or abrupt increase in gate resistance.
- B. Flashing:** Overload.
Detected a more subtle, but sustained increase in gate resistance.

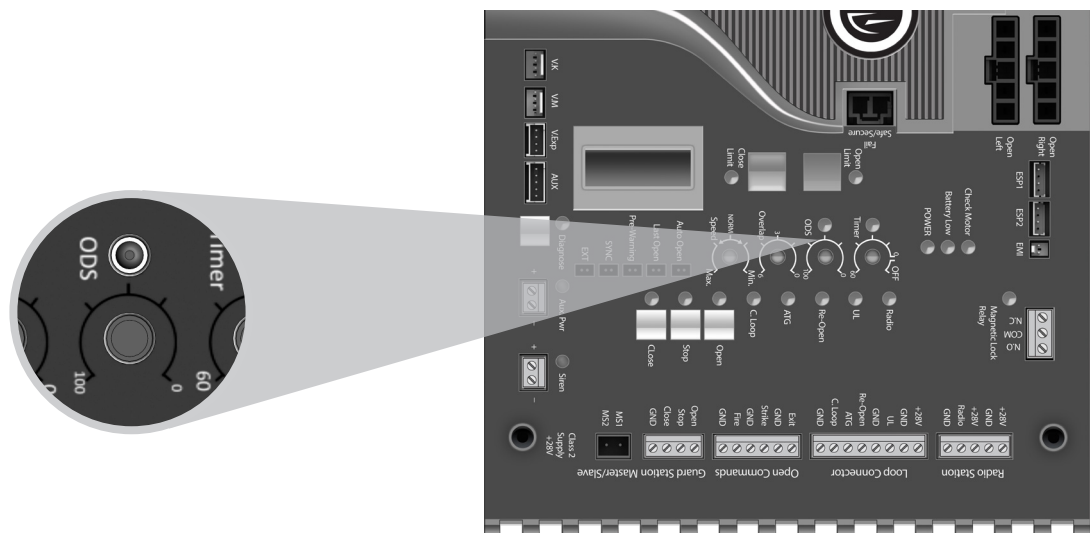

CONTROL BOARD SETUP

Viking Heater

The operator has an integrated heater. Activate this feature when the operator is used in application temperatures down to -20°F (-29°C).

 Disabled when “Solar Mode” is ON.

To set the heater to turn on at the Close Limit:

1. Use the “Diagnose” button to scroll through the LCD Display to “HEATER CLS”
2. Press and hold the “Stop” button on the control board.
3. Press and release the “Diagnose” button to turn this feature ON and OFF.



To set the heater to turn on at the Open Limit:

1. Use the “Diagnose” button to scroll through the LCD Display to “HEATER OPN”
2. Perform steps 2-3 as described above.



NOTE: If the application requires the gate to be held open for any reason, set the HEATER ON for both limit positions.

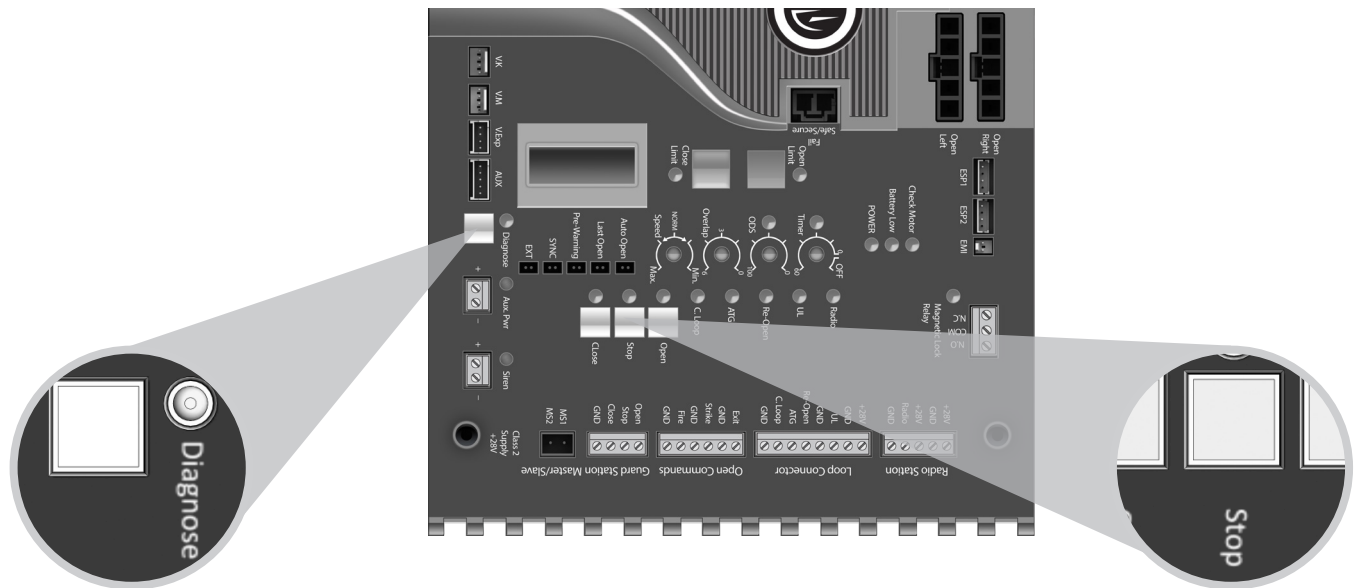

ACCESSORY CONNECTIONS

UL (Monitored Input Terminal)

The “UL” input terminal protects against entrapment in both the opening and closing directions. Input will reverse the gate momentarily in the opposite direction it was traveling when a connected device it triggered. see pages 10-11.

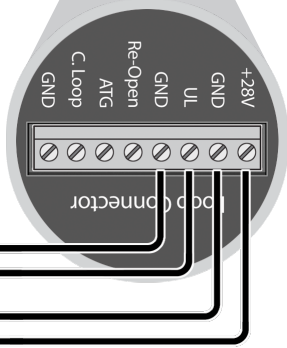
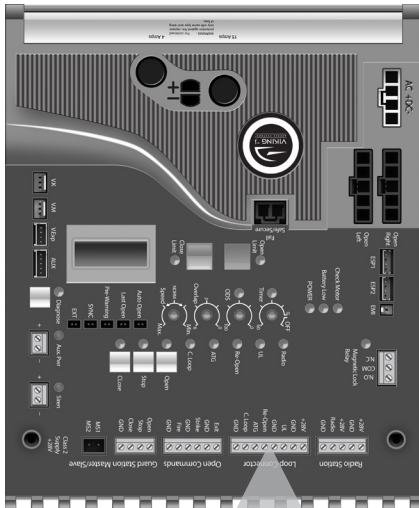

Check for proper operation:

When a connected device is triggered, the “UL” LED will illuminate and, if more than one Monitored device connected, the “Stop” LED will flash rapidly to indicate an input.

⚠ If more than one Monitored device is connected to this terminal, the “UL” LED will be illuminated. This alone is inconsequential.

⚠ **TECHNICAL TIP:** For more information regarding accessory connections to the control board and individual input terminal functions, refer to “Appendix (A)” pages 42-43.

Re-Open (Monitored Input Terminal)

The “Re-Open” input terminal protects against entrapment in the closing direction ONLY. Input will reverse the gate all the way to the Open Limit when a connected device it triggered. see pages 10-11.

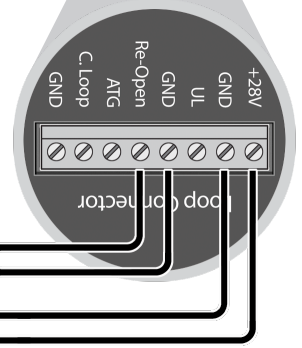
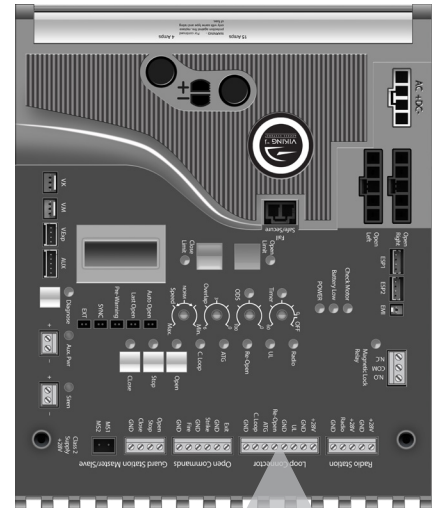

Check for proper operation:

When a connected device is triggered, the “Re-Open” LED will illuminate and, if more than one Monitored device connected, the “Stop” LED will flash rapidly to indicate an input.

⚠ If more than one Monitored device is connected to this terminal, the “Re-Open” LED will be illuminated. This alone is inconsequential.

NOTE: The “Stop” LED will be flashing if there is a failure with at least one monitored entrapment sensor and the gate operator will be rendered inoperable.

ACCESSORY CONNECTIONS

Radio Receiver (Typical)

⚠ IMPORTANT: The Hold Open “Timer” setting (page 25) affects how the gate will respond to the radio receiver command.

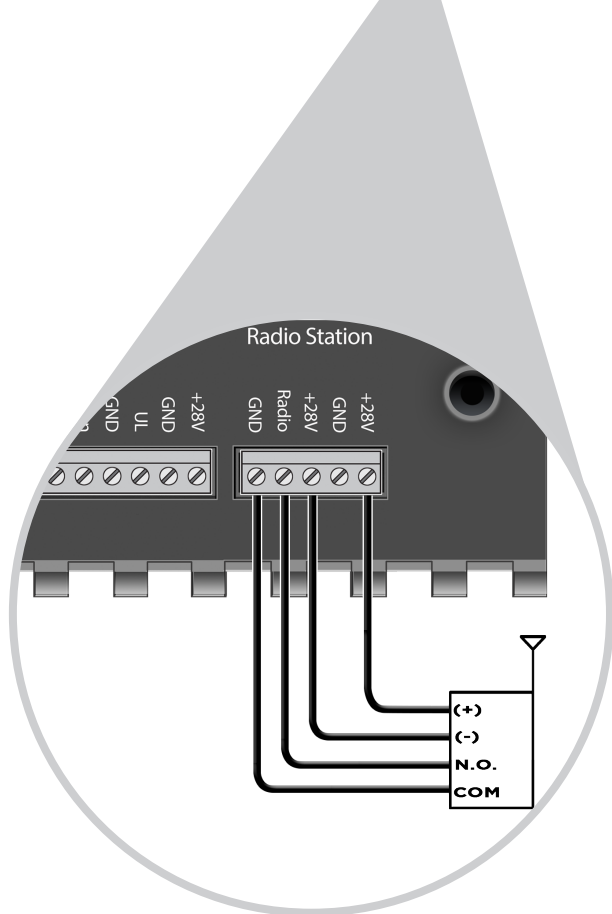
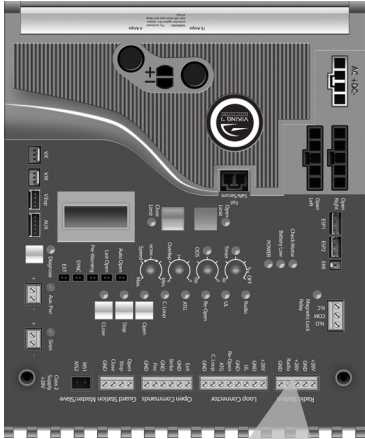

⚠ TECHNICAL TIP: For more information regarding accessory connections and terminal functions, refer to “Appendix (A)” on pages 42-43.

The control board provides two modes of operation that a radio receiver can control the gate:

1. Open-Stop-Close

By having the radio receiver connected as illustrated and with the “Timer” OFF (see page 25):

Every command of the radio transmitter will control the gate as follows:

- First command opens the gate,
- Second command stops the gate and
- Third command closes the gate
- Any subsequent commands will continue in the same order to control the gate.

This type of configuration is not recommended for commercial installations.

2. Open Only

By having the radio receiver connected as illustrated and with the “Timer” ON (see page 25):

Each command of the radio transmitter is **ALWAYS AN OPEN COMMAND** to the gate.

ACCESSORY CONNECTIONS

Anti-Tailgate, Open Commands & Guard Station

⚠ TECHNICAL TIP: For more information regarding accessory connections and terminal functions, refer to “Appendix (A)” on pages 42-43.

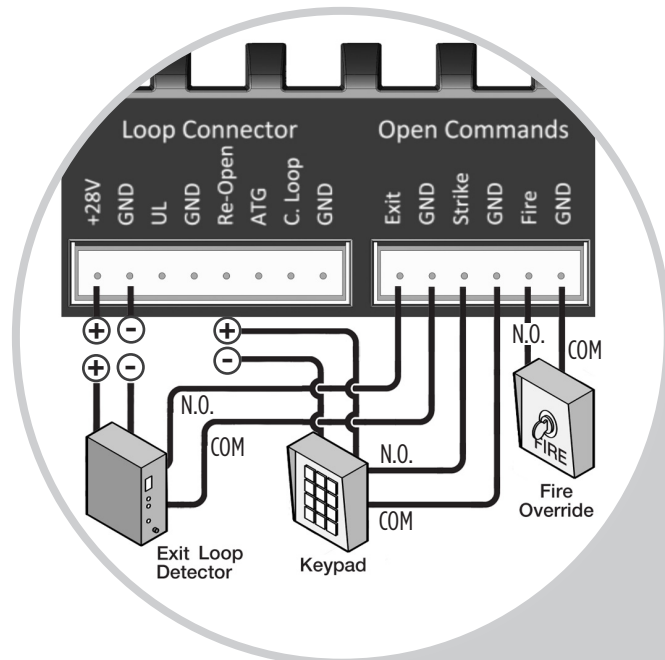

Open Commands

“Exit”, “Fire” and “Strike” input terminals all provide an open command to the control board. Any device connected as shown will open the gate.

Guard Station

⚠ All three buttons must be a Normally Open “N.O.” type of switch, and can share the same common “C” connection to “GND”.

“ATG” Anti-Tailgate

This input will stop the gate when the vehicle triggers the sensor, then closes the gate when the vehicle leaves the sensor, preventing unauthorized vehicles from entry.

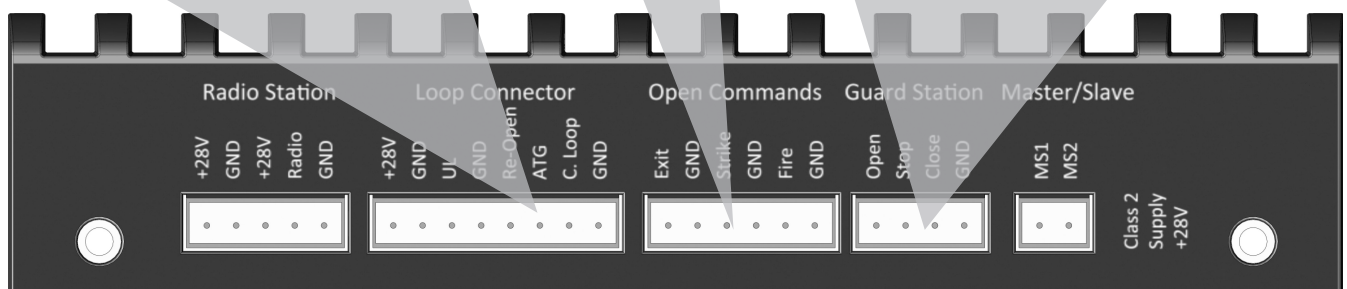
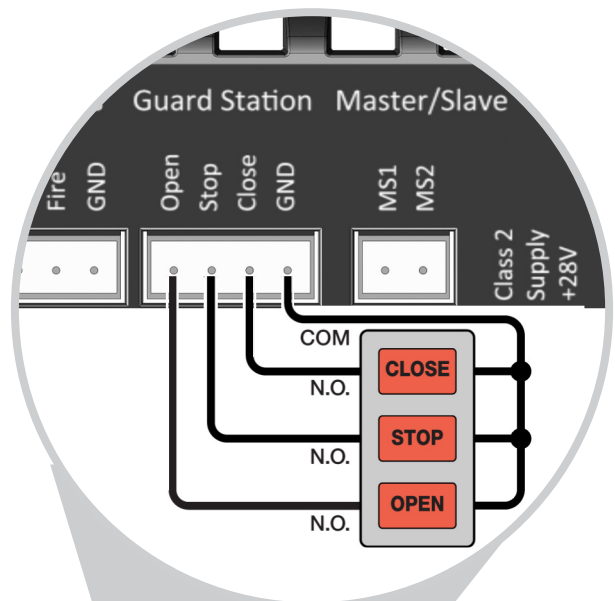
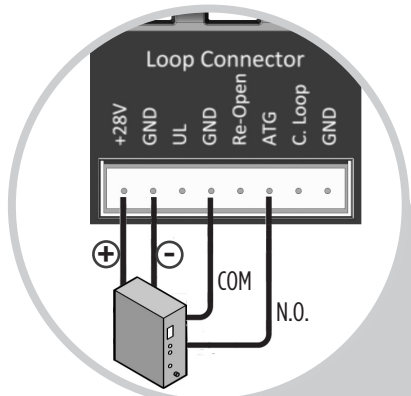

ACCESSORY CONNECTIONS

Viking Loop Rack

TIP: This operator may be equipped with a pre-wired **Loop Rack** that plug-in type loop detectors can be connected to. This provides a convenient alternative to the box type loop detectors that would need to be wired to the control board. Viking does not provide either type of loop detectors.

Loop Rack: Part # VA-LR

Loop Rack Wiring Harness: Part # VA-LRH

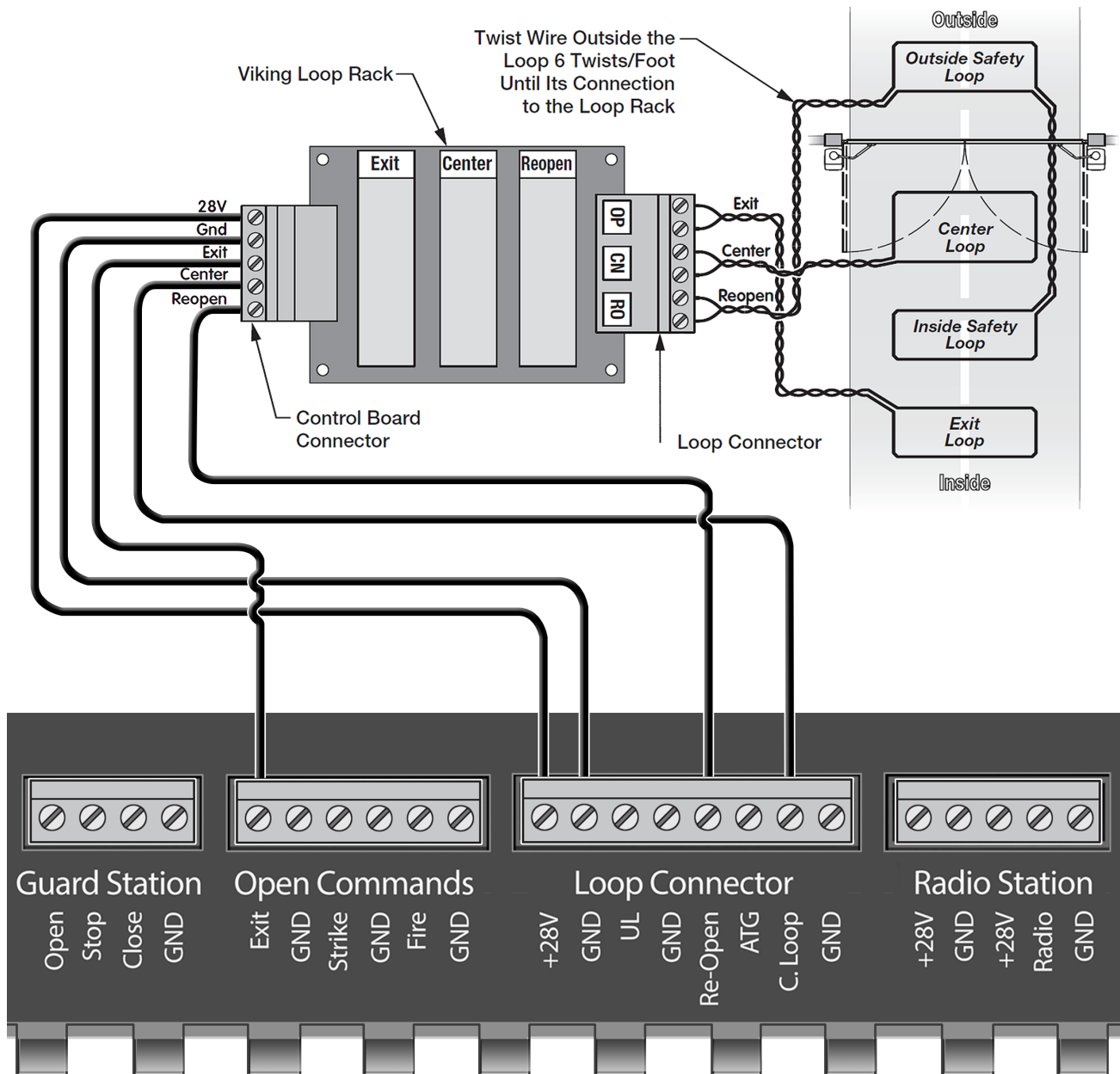

ACCESSORY CONNECTIONS

Guidelines for Loop Installation

1. Prevent sharp corners in the geometry of the loop sensor.
2. Install the appropriate number of turns for your loop geometry based on the loop perimeter. Use Table C (below) as a guide.
3. Use XLP (cross-linked-polyethylene) type of wire. This wire reduces the effects of moisture and other environmental events in altering the functionality of the vehicular loop detector.
4. Twist the lead wire at least 6 turns per foot.
5. Use BACKER-ROD to minimize damage to the loop detector wire prior to using the sealant.
6. Place the loop detector wire and adjust the sensitivity of the vehicular loop detector unit in a way to minimize the effects of the gate over the loop detector wire.

⚠ IMPORTANT! Some of the following parameters may affect the proper functionality of the vehicular loop detector.

Consult the manufacturer of the vehicular loop detector and/or loop wire.

- Gate size
- Number of turns in the loop sensor wire
- Distance of the loop sensor wire to the gate at either at the open or close position

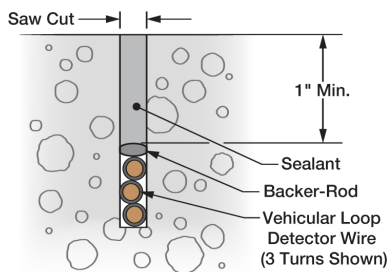
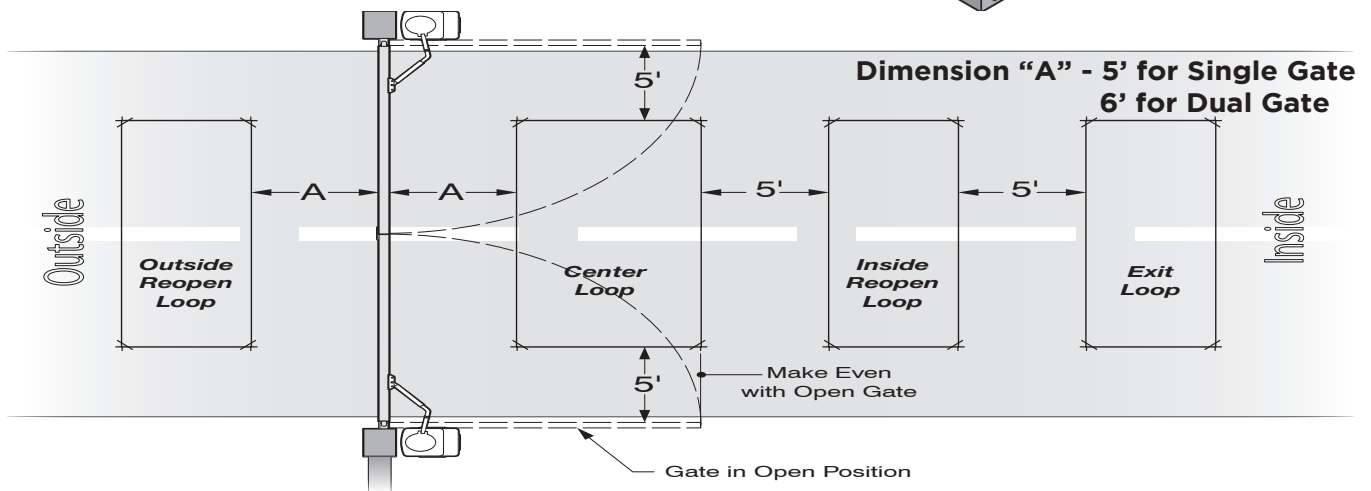
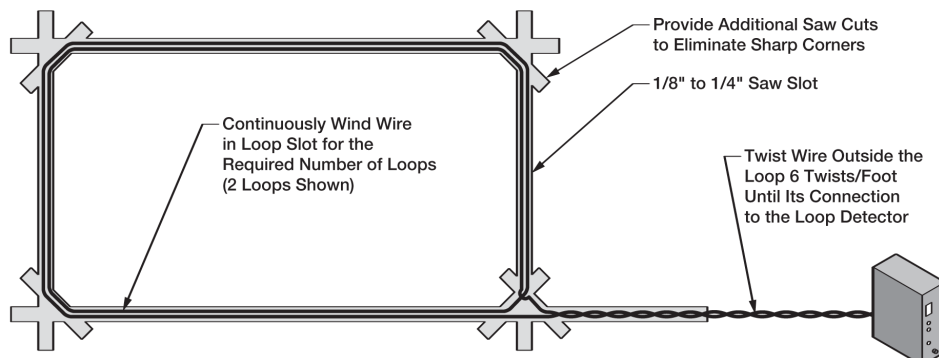

Table C - Recommended Number of Turns

Perimeter (ft.)	Number of Turns
10	5
20	4
30-40	3
50-100	2



ACCESSORY CONNECTIONS

Magnetic Lock, Lock Solenoid

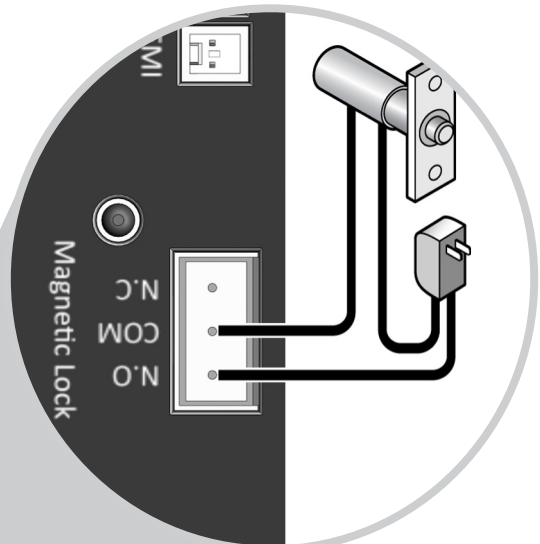
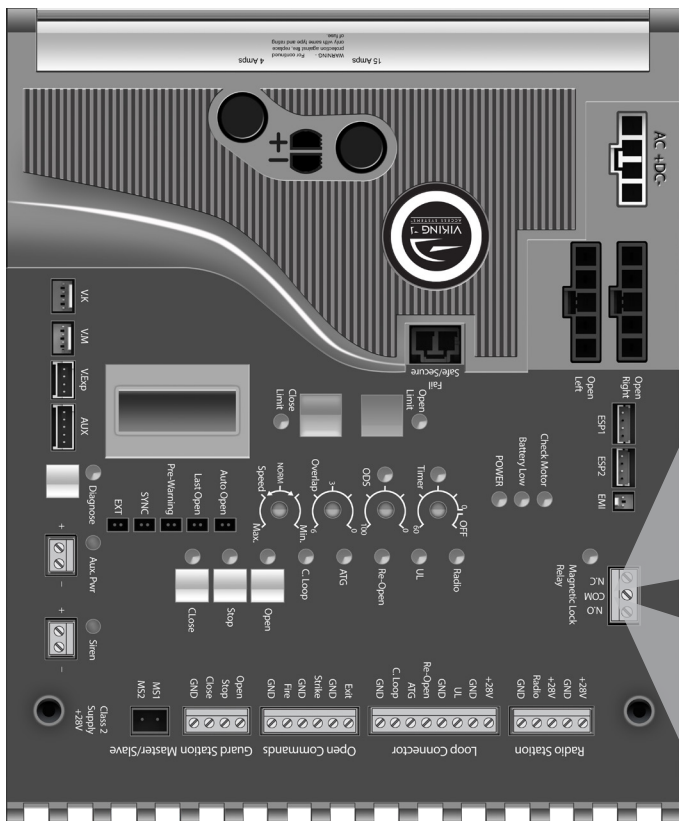

Lock Solenoid

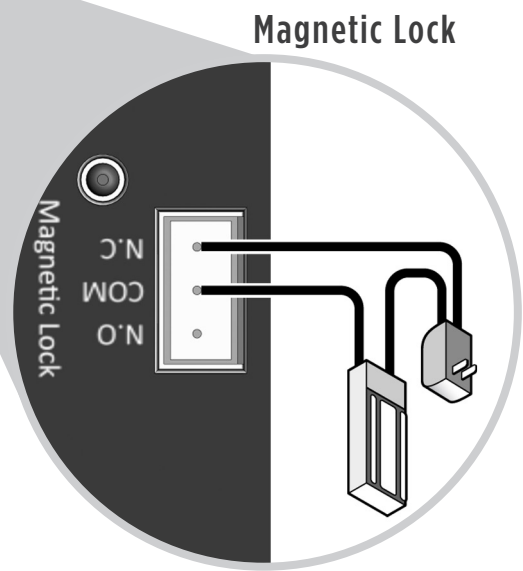

Magnetic Lock

Power for the Locks:

Do not use the 24VDC power supplied by the control board. An external power supply, or plug-in transformer, must be used for the magnetic lock or lock solenoid. This will prevent rapid drainage of the battery in the event of power failure.

The control boards "Magnetic Lock" relay is rated for 10A-250VAC.

⚠ TECHNICAL TIP: The Magnetic Lock Relay LED will indicate status of the on-board relay even if a lock is not connected to the control board. Refer to page 36.

ACCESSORY CONNECTIONS

Barrier Arm Synchronization

NOTE: The Control Board provides a convenient solution for applications that require synchronized operation with the Barrier Arm Operator.

This type of application opens and closes in the following pattern:

1. Open Command is provided only to the Barrier Arm operator.
2. The Barrier Arm will send an open input to the Viking gate operator; Barrier Arm will delay to open until the Viking gate operator reaches its Open Limit.
3. Barrier Arm will close first; the Viking gate operator will delay to close until the Barrier Arm reaches its Close Limit.

STEP 1 (Figure A)

At the Barrier Arm operator, connect the device(s) that will be used as the primary OPEN input.

STEP 2 (Figure A & B)

Connect the Barrier Arms' designated sync output terminals to the Strike input at the Viking gate operator.

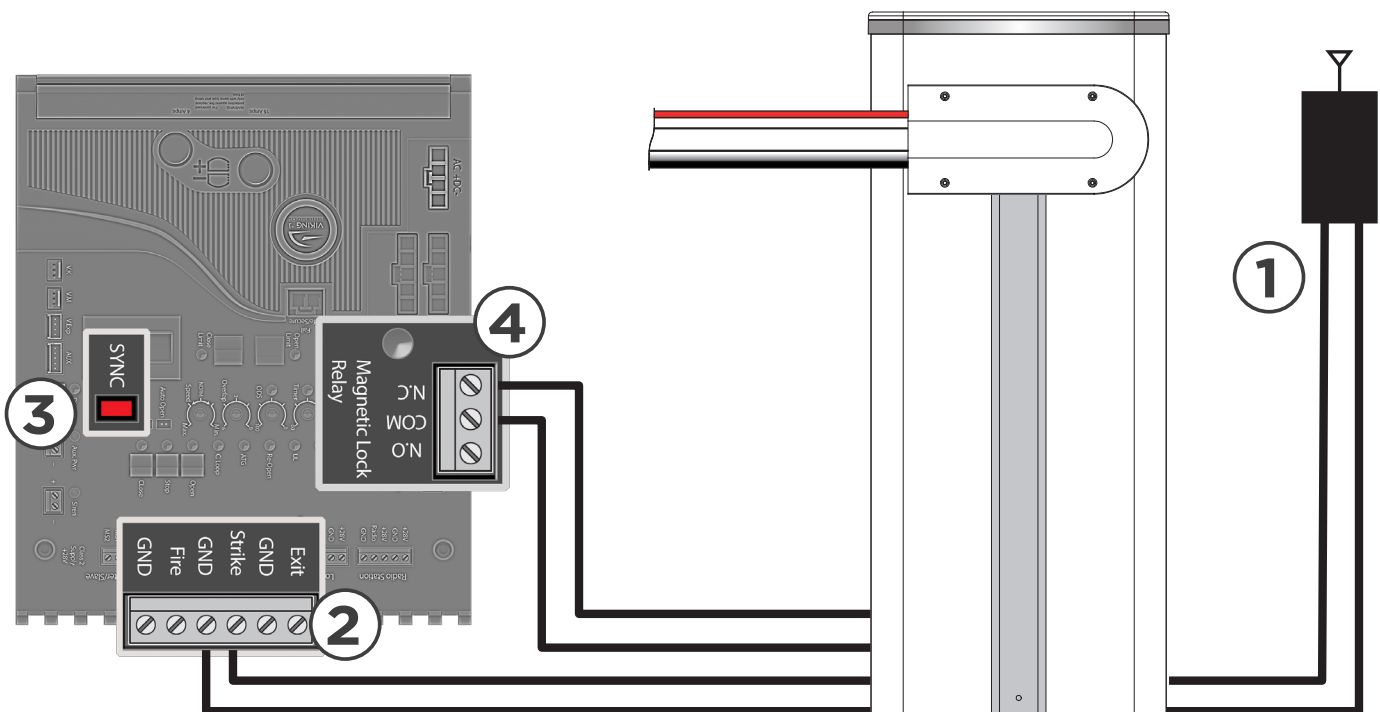

STEP 3

At the Viking gate operator, activate Sync Mode by placing a jumper on to the pin headers labeled "SYNC".

STEP 4

Connect Magnetic Lock relay terminals ("COM" and "N.C.") to the Barrier Arms' designated sync input terminals.

TROUBLESHOOTING

LED References

In addition to the LCD Display, the control board LEDs monitor the various circuits of the control board. Use the table below to identify the corresponding “TS Ref#” and refer to pages 36-41 for further troubleshooting.

SLAVE MODULE (pg. 37)

EMI BOARD (pg. 37)

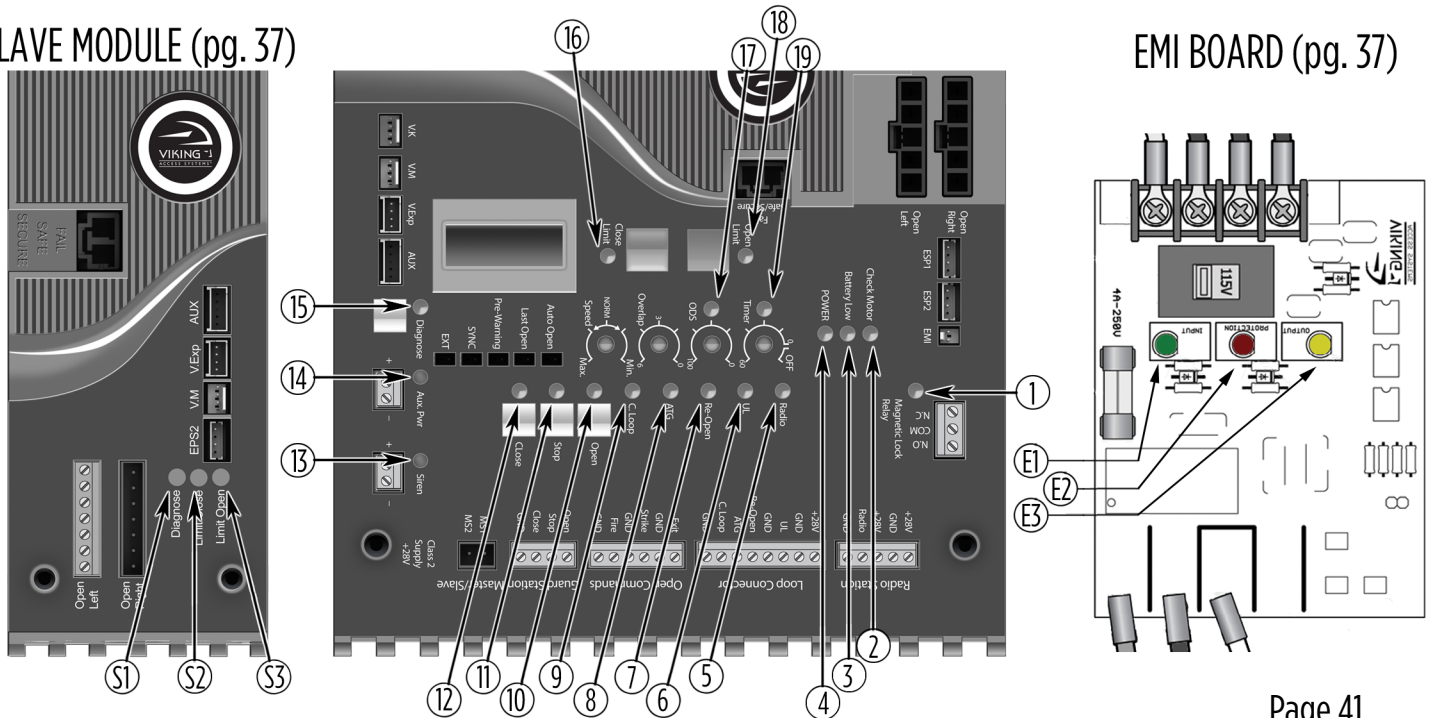

#	LED	Status	Meaning	TS Ref#(s)
1	"Magnetic Lock Relay"	OFF	At Closed Limit and Magnetic Lock Relay state is closed across "COM" & "N.C.". (pg 34). Gate should be at the Close Limit.	
		SOLID	Not at Closed Limit and Magnetic Lock Relay state is closed across "COM" & "N.O.". (pg 34). Gate should not be at the Close Limit.	
2	"Check Motor"	OFF	Normal Condition.	
		SOLID	The control board is sending power to the motor but the circuit is open.	7, 8
3	"Battery Low"	OFF	Normal Condition.	
		SOLID	Batteries are low. Check power supply to the operator. (pg 20-21)	1, 2
		FLASHING	Batteries critically low. Check power supply to the operator. (pg 20-21)	1, 2
4	"POWER"	SOLID	Normal Condition.	
		FLASHING	Operator is running on batteries only. (pg 20-21)	1, 2
		OFF	No power to control board.	1, 2, 4, 5
5	"Radio"	OFF	Normal Condition.	
		SOLID	Control Board is receiving an input from a device connected to the Radio terminal. (pg 30, 42)	9, 10
6	"UL"	OFF	Normal Condition.	
		SOLID	Control Board is receiving an input from a device connected to the UL terminal or when more than one device is connected (pg 10-11, 28, 42).	9, 10, 16, 22
7	"Re-Open"	OFF	Normal Condition.	
		SOLID	Control Board is receiving an input from a device connected to the Re-Open terminal or when more than one device is connected (pg 10-11, 29, 32, 42).	9, 10, 16, 22
8	"ATG"	OFF	Normal Condition.	
		SOLID	Control Board is receiving an input from a device connected to the ATG terminal. (pg 31, 42)	9, 10

#	LED	Status	Meaning	TS Ref#(s)
9	"C Loop"	OFF	Normal Condition.	
		SOLID	An input from a device connected to the C Loop terminal. (pg 32, 42)	9, 10
10	"Open"	OFF	Normal Condition.	
		SOLID	An input from a device to Exit, Fire, Strike or Open terminal. (pg 31, 42)	9, 10
11	"STOP"	OFF	Normal Condition.	
		SOLID	Control Board is receiving an input from a device connected to the Stop, UL or Re-Open terminals (pg 31, 42)	9, 10
		FLASHING	There is a problem with the required monitored sensor(s) connected to the "UL" and/or "Re-Open" input terminals (pg 10-11, 22 and 29)	16, 22
12	"Close"	OFF	Normal Condition.	
		SOLID	An input from a device connected to the Close terminal. (pg 31, 42)	9, 10
13	"Siren"	OFF	Normal Condition.	
		SOLID	Second consecutive obstruction has been detected. (pg 25, 27)	11, 13, 1, 2
		FLASHING	Batteries are critically low.	1, 2
14	"Aux. Pwr"	OFF	No voltage output on these terminals at the moment.	
		SOLID	There is 24V DC output on these terminals at the moment.	
15	"Diagnose" (Primary)	OFF	Normal Condition	
		FLASHING	Errors have been detected; Check LCD Display for ERR messages. (pg 40)	
16	"Close Limit" (Primary)	OFF	Gate is not at the close limit position.	
		SOLID	Gate is at the close limit position.	
		FLASHING	Control Board does not recognize the operator model as an I770	6
17	"Open Limit" (Primary)	OFF	Gate is not at the open limit position.	
		SOLID	Gate is at the open limit position.	
		FLASHING	Control Board does not recognize the operator model as an I770	6
18	"ODS"	OFF	Normal Condition.	
		SOLID	Obstruction event has been detected on the Primary motor. (pg 25, 27)	11, 13, 1, 2
		FLASHING	Overload event has been detected on the Primary motor. (pg 25, 27)	11, 13, 1, 2
19	"Timer"	OFF	If gate is at the open limit, the Timer to close is turned OFF. (pg 25)	
		SOLID	Timer to close is ON and counting down to close the gate. (pg 25)	
		FLASHING	Timer is ON but is not timing out due to a conflicting command. (pg 25)	9, 10
S1	"Diagnose" (Secondary)	OFF	Normal Condition	
		FLASHING	Errors have been detected; Check LCD Display for ERR messages. (pg 40)	
		SOLID	Obstruction event has been detected on the Secondary motor. (pg 25, 27)	11, 13, 1, 2
		RAPID FLSH	Overload event has been detected on the Secondary motor. (pg 25, 27)	11, 13, 1, 2
S2	"Limit Close" (Secondary)	OFF	Secondary gate is not at the close limit position.	
		SOLID	Secondary gate is at the close limit position.	
S3	"Limit Open" (Secondary)	OFF	Secondary gate is not at the open limit position.	
		SOLID	Secondary gate is at the open limit position.	
E1	"AC VOLTAGE INPUT"	SOLID	Normal Condition.	
		OFF	Incoming power to the EMI Board is not sufficient..(pg 20)	1
E2	"PROTECTION WORKING"	SOLID	Normal Condition.	
		OFF	EMI Board is damaged and circuit is not protected . Replace EMI Board.	
E3	"AC VOLTAGE OUTPUT"	SOLID	Normal Condition.	
		OFF	There is no output voltage from the EMI Board.	2

TROUBLESHOOTING

LCD Display References

The control board is equipped with a LCD Display that provides operator information, current conditions, settings, diagnostics and error messages. Use the table below to identify the corresponding "TS Ref#" and refer to page 37 for further troubleshooting.

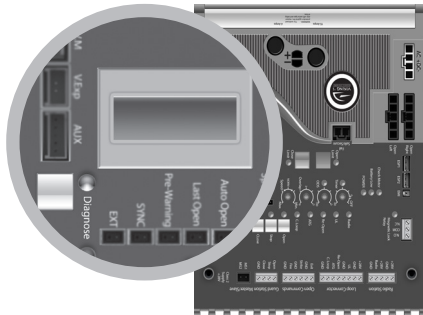

1. Error Messages will be displayed first.
2. The "Diagnose" LED will flash consecutively indicating how many Error Messages are available.
3. Press the Diagnose button to manually scroll through all of the Messages.

Page 41
TS Ref #s

LCD MSG	Meaning	
MODEL I770	Indicates the Model of the unit. I-770	
System Status Messages		
GATE IS IDLE	Gate is stopped between limits.	
GATE IS OPENING	Gate is opening.	
GATE IS CLOSING	Gate is closing.	
GATE IS OPENED	Gate is at the limit open position.	
GATE IS CLOSED	Gate is at the limit close position.	
STOP BY OBSTRUCT	Primary or Single motor has stopped due to an obstruction of the gate system. Also refer to the "ODS" LED. (pg 25, 27, 36 @ #4, 37 @ #18)	11, 12, 13
STOP BY OVERLOAD	Primary or Single motor has stopped due to an overload of the gate system. Also refer to the "ODS" LED. (pg 25, 27, 36 @ #4, 37 @ #18)	11, 12
OVERLAP TIMING	Gate is waiting for the overlap time.	
HOLDING ... SEC	Gate is at the limit open position and timing to close - The display shows the actual time left before closing.	
STOP BY ODS S	Secondary motor has stopped due to an obstruction sensor event. Also refer to the "DIAGNOSE" LED on the Secondary Module. (pg 25, 27, 36 @ #4, 37 @ #S1)	11, 12, 13
UL LEARN UL... RO...	Indicates the number of connected Monitored Entrapment Protection Sensors that are being monitored. NO LEARN = no sensors learned. (pg 11)	

LCD Display References

Page 41
TS Ref #s

LCD MSG	Meaning
RED CONN UNPLUGED	The Motor Connector is not plugged into the red Open Left or Open Right socket at the control board. (pg 3, 22)

23

Multi Meter Displays

MOT AMP ---- A	This is the motor current amperage during operation.
-------------------	--

MOT VOLT ---- VDC	This is the actual motor voltage during operation.
----------------------	--

AC VOLT ---- VAC	This is the actual low voltage AC to the Control Board from the transformer.
---------------------	--

CHARGE ---- VDC	Indicates the charging voltage to the batteries, if the Battery Switch is in the OFF position.
--------------------	--

BAT VOLT ---- VDC	Indicates battery voltage, if the AC power is discontinued to the Control Board.
----------------------	--

Board Settings Messages

SPEED ___%	Shows the percentage of speed set by the Speed adjustment on the control board. (pg 25)
---------------	---

OVERLAP ... SEC	Shows the number of seconds set by the Overlap Adjustment on the control board.
--------------------	---

OBST SENS ----%	Shows the force setting selected to trip the obstruction sensor. (pg 25, 27)
--------------------	--

TIMER __ SEC	Shows the amount time set or remaining to hold the gate at the Open Limit position, before the gate starts to close. (pg 25)
-----------------	--

HEATER CLS OFF	The Integrated Heater has been disabled for the Closed Limit. (pg 28)
-------------------	---

HEATER CLS ON	The Integrated Heater has been enabled to turn on at the Close Limit position (pg 28) "ACTIVE" will be displayed while it is heating.
------------------	---

HEATER OPN OFF	The integrated Heater has been disabled for the Open Limit. (pg 28)
-------------------	---

HEATER OPN ON	The Integrated Heater has been enabled to turn on at the Open Limit position (pg 28) "ACTIVE" will be displayed while it is heating.
------------------	--

SOLAR MODE OFF	The Solar Mode feature is turned OFF. (pg 21, 45)
-------------------	---

SOLAR MODE ON	The Solar Mode feature is turned ON. (pg 21, 45)
------------------	--

TROUBLESHOOTING

LCD Display References

Page 41
TS Ref #s

LCD MSG	Meaning	
Error Messages		
ERR AC LOW	Indicates that the 24VAC supply to the VFlex Board is too low from the 115/230 power supply.	1, 3, 20
ERR AC HIGH	Indicates that the 24VAC supply to the VFlex Board is too high from the 115/230 power supply.	1, 3, 20
ERR AC NO AC	Indicates that there is no 24VAC supply detected to the VFlex Board from the 115/230 power supply.	1, 2, 4, 20
ERR CHRG HIGH	Potential problem with the charging voltage from the control board.	1, ?
ERR CHRG CHECK 4A	a) 4 Amp Fuse is blown, or; b) There is a problem with the batteries or the control board.	18, ?
ERR BAT LOW	The battery is low.	1, 2, 3, 4
ERR FUSE 15 AMP	15 Amp motor fuse is blown on the Primary or Single Control Board.	7, 11, 12
ERR EMI NO EMI	No EMI board detected.	15
ERR EMI NO FUSE	4 Amp main fuse is blown on Power Supply Panel Assembly.	2
ERR EMI NO AC	There is no AC voltage detected from the EMI Board.	20
ERR EMI UNKNOWN	There is a problem with the communication between the EMI Board and the VFlex Board.	21
ERR EMI PROTECT	Lightning strike protection for the EMI Board (behind the Control Board assembly) needs to be replaced.	?
ERR FUSE 15A S	15 Amp motor fuse is blown on the Secondary Module.	7, 11, 12
ERR REFV WRONG	One, or more, of the internal reference voltages from the VFlex (Primary) Control Board are incorrect.	?
ERR SENS UL RO	There is a problem with the required monitored sensor(s) connected to the "UL" and/or "Re-Open" input terminals (pg 10-11, 29).	22
ERRLIMIT OPN+CLS	There is a problem with the Limit Switches or Wires.	6, 24

TROUBLESHOOTING

Solutions

Begin the troubleshooting process by referring to the error messages on the LCD Display and/or the Status LEDs on the control board. Use pages 36-40 to identify the Troubleshooting Reference # (TS Ref#) then reference the table below.

TS Ref#	CHECK	Page Ref#
1	Check that the high voltage power supplied to “EMI Board” is within range. 100V-120V or 200V-240V	pg 20
2	Remove and check EMI Fuse for continuity.	pg 20
3	Check that the “Voltage Selector”, on the EMI Board, is set according to the high voltage power supply. 115V AC or 230V AC	pg 20
4	Not applicable to this model	
5	Check that the Power Harness is connected to the control board.	pg 3, 20-21
6	Check that the operator model displayed on the LCD Display is correct.	pg 22, 23
7	Check Motor Fuse on the control board.	pg 3
8	Check for an open circuit to the motor.	
9	Check the Status LEDs and LCD Display to determine if the control board is receiving an input from any external devices or if the “ODS” has been triggered.	pg 25, 27 36-38
10	Remove the external devices from the control board to determine if the control board is responding to an input or problem with the external device or wiring.	pg 29-32, 36-37
11	Check the “ODS” setting on the control board.	pg 27
12	Check that the gate can be moved manually with low resistance throughout its full range of motion.	pg 8, 11
13	Check the limit position.	pg 3, 18
14	Not applicable to this model	
15	Check that the EMI cable is properly connected to the “EMI” connection at the VFlex control board and at the EMI Board.	pg 3, 20
16	Check the LCD Display for Error Messages	pg 40
17	Not applicable to this model	
18	Check 4 Amp fuse on the control board	pg 3
19	Manually adjust any setting on the Control Board to clear all wireless override settings	
20	Check for 24VAC out from the Toroidal Transformer and Power Harness	pg 3, 20
21	Check the EMI Cable and contacts between the EMI Board and the VFlex Board	pg 3
22	Check the required entrapment protection sensors.	pg 7, 10-11, 29
23	Check that the Motor Harness and Connector is connected to the control board.	pg 3, 22
24	Not applicable to this model	
?	The Control Board or EMI board may be damaged. Call Viking Technical Support for further assistance	

Appendix (A)

Access Control Connections

Power Connections

The control board provides a 24VDC output to power external devices and controls.

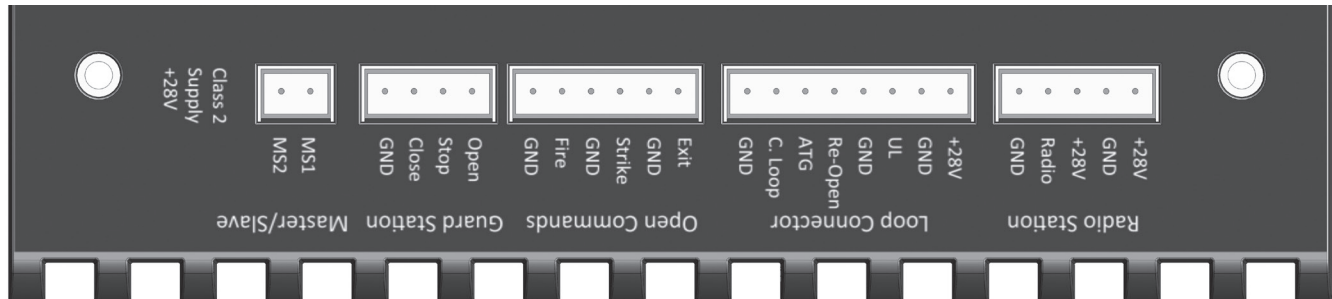

“C” = Common
 “N.O.” = Normally Open

Terminals Connections and Input Functions:

Viking Terminal	Function	Device Terminal
“+28V”	DC Positive	“+”
“GND”	DC Negative	“-”
“GND”	Relay Common	“C”
“Radio”		“N.O.”
	If “Timer” OFF: Open - Stop - Close If “Timer” ON: Open / Reopen if closing	
“UL”	(see pages 10-11 & 29)	“N.O.”
	If stopped: Prevents the gate from moving If traveling: Stops then reverses gate momentarily	
“Re-Open”	(see pages 10-11 & 29)	“N.O.”
	If stopped: No function If closing: Stops then Opens gate	
“ATG” Anti-Tailgate		“N.O.”
	Input is received: Stops gate if closing Input is released: Closes gate to prevent tailgating	
“C. Loop”		“N.O.”
	If not at open limit: No function If at open limit: Prevents gate from Closing	
“Open”, “Exit”, “Fire” & “Strike”		“N.O.”
	If stopped: Opens gate If closing: Stops then Opens gate	
“Stop”		“N.O.”
	If traveling: Stops gate	
“Close”		“N.O.”
	If stopped: Closes gate If traveling: No function	

⚠ TECHNICAL TIP: Each input Terminal (i.e. Radio, Exit, Re-Open, UL) has a corresponding Status LED that when illuminated indicates an input is currently being provided to the terminal and the gate is responding accordingly. (See pages 36-37 LED References)

Relays In General

In General

In regards to the Viking control board, all external safety devices and access controls contain, and are, simple relays that provide an input to the Viking control board when the device is activated.

When these devices are activated, their internal relays create a contact, or short, between the “C” and “N.O.” terminals. This contact is what provides the command to the Viking control board.

⚠ TECHNICAL TIP: Viking uses the Normally Open “N.O.” contact from the device, excluding “fail-safe” type photo beams. In such instances, the Normally Closed “N.C.” will be used instead.

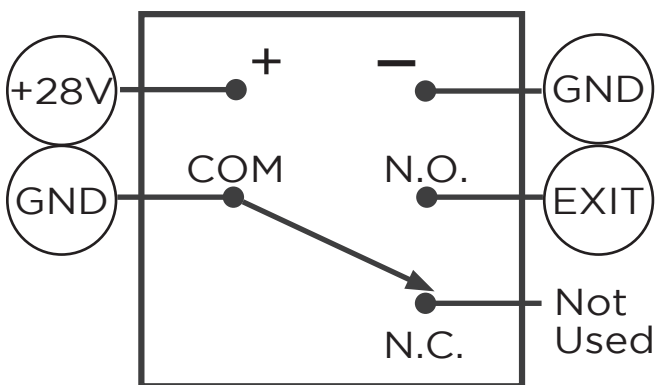

Glossary of Terms

- 1. Terminal:** Wire Connections.
- 2. Input Terminal:** On the Viking control board, the terminal which is labeled for a specific command (Re-Open, Exit, Radio, etc.). The N.O. contact from the access control device is to be connected to the Input Terminal.
- 3. Terminal Block:** On the Viking control board, a removable block containing multiple terminals.
- 4. Relay:** The component of an access control or safety device that provides an input or command to the Viking control board.
- 5. “C” Relay Common Terminal:** This is the relay terminal that makes contact (a short) to the N.O. terminal when the device is activated. *Always wire this relay terminal to any “GND” terminal at the control board.*
- 6. “N.O.” Relay Normally Open Terminal:** The relay terminal that has an open contact to “C” while the relay is not activated, and a closed contact when the relay is activated. *Almost always wire this relay terminal to an “Input Terminal” at the control board,*
- 7. “N.C.” Relay Normally Closed Terminal:** The relay terminal that has a closed contact to “C” while the relay is not activated, and an open contact when the relay is activated. *This terminal is rarely used.*
- 8. Relay Coil:** Contains the terminals that provide power at the relay.
- 9. “+” Relay Positive Terminal:** The positive power pole for the relay coil. *Always wire this relay terminal to any “+28V” terminal at the control board.*
- 10. “-” Relay Negative Terminal:** The negative power pole for the relay coil. *Always wire this relay terminal to any “GND” terminal at the control board.*

Appendix (B)

Photobeam Connections - Example

FA-XP30-10K

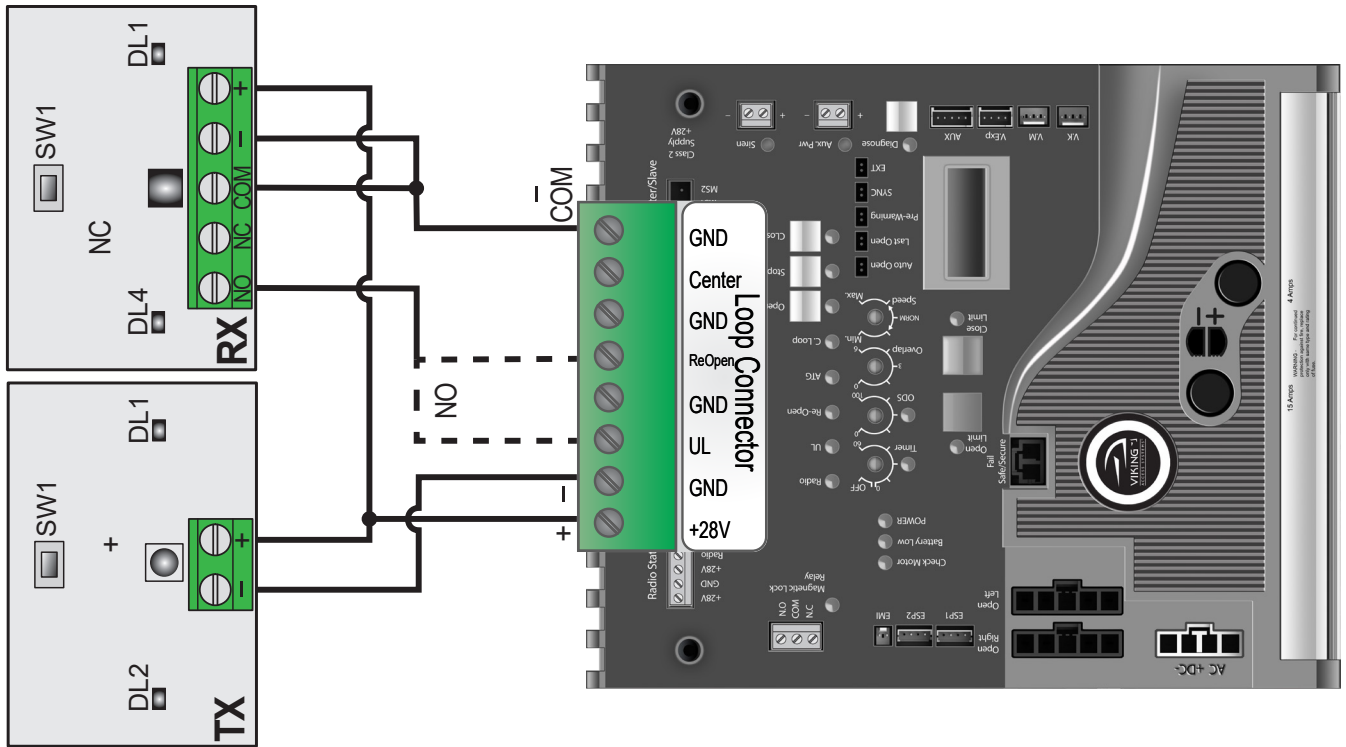

Solar Mode

NOTE: Viking recommends Solar Package (**part # VA-SOCHP**) for most general solar applications. Alternatively, individual and third party solar components can be used.

To Turn ON Solar Mode:

- A. Use the “Diagnose” button to scroll through the LCD Display to “SOLAR MODE”. Default setting is OFF.
- B. Press and hold the “Stop” button on the control board.
- C. Press and release the “Diagnose” button to toggle this feature ON and OFF.

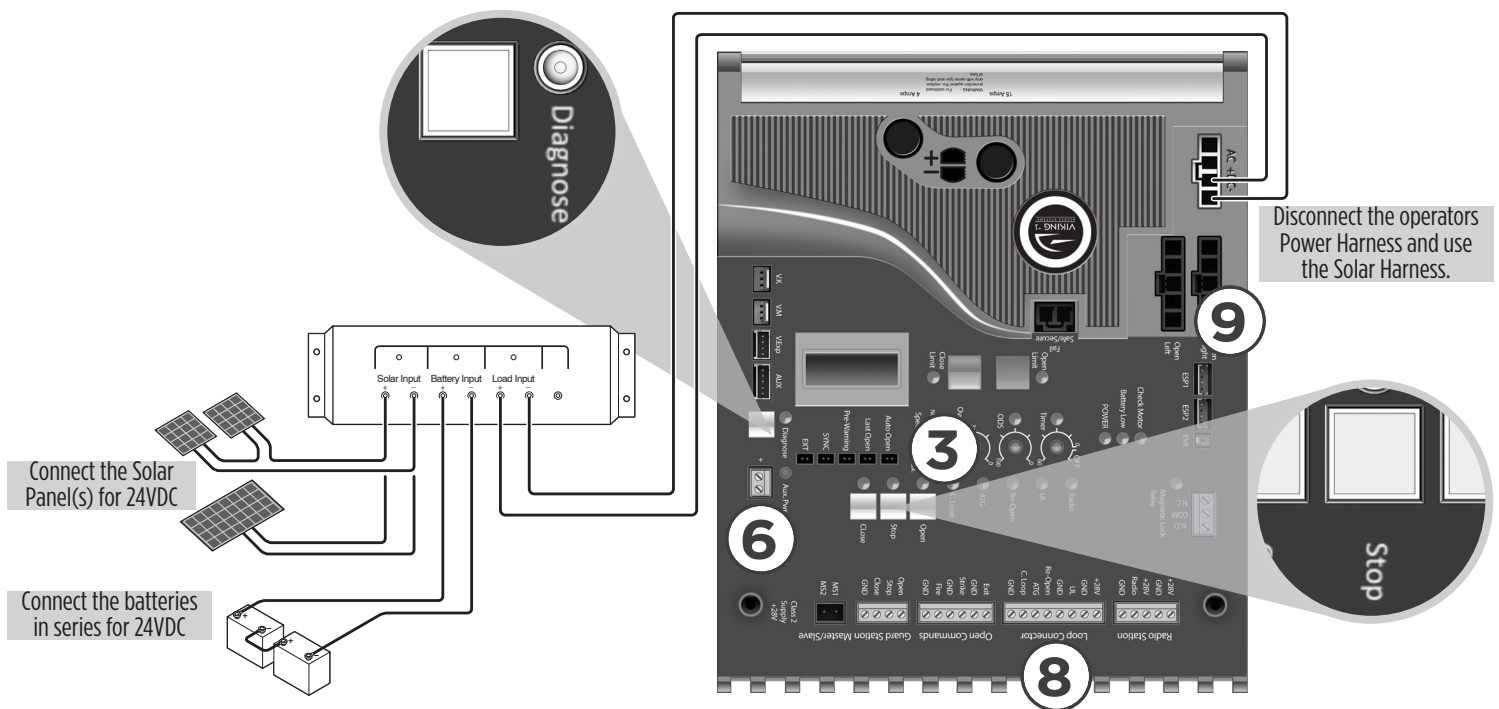

Solar Mode will change the following:

1. Viking Wireless Konnect Modules are **not** compatible for Solar Mode.
2. Heaters will be disabled. Refer to page 28.
3. Auto Open feature will be disabled. Refer to page 3, 26.
4. Last Open feature will be available. Refer to page 3, 26.
5. Control Board will go to sleep when idle for 10 seconds.
6. While in sleep, there will be no power supplied from Aux PWR. Refer to pages 3, 21.
7. While awake, there will always be power supplied from Aux PWR. Refer to pages 3, 21.
8. While in sleep, all Loop Connector safety inputs will be ignored. Center, Re-Open and UL.
9. When waking from sleep, there will be a 2 second delay before the motor responds to open or close. This will allow time for the safety devices to power up and stabilize.

If more specific information is needed please consult with Viking Access Systems. For more information regarding solar energy refer to www.nrel.gov/solar

(THIS PAGE LEFT BLANK INTENTIONALLY)

(THIS PAGE LEFT BLANK INTENTIONALLY)

VIKING EXPANSION PRODUCTS



VIKING KONNECT Primary/Secondary Kit Secure and reliable Primary/Secondary communication between two single gate operators or ECU's using Viking's Konnect technology.

Part# VA-KONNECT-MS

Q-7 & ECU Operators require (2) Antenna Extension Cables (part# VA-RPSMA)

*** NOT COMPATIBLE for Solar Mode setting on Control Board***



VIKING MONITOR Off-site access to operator diagnostics and perform firmware updates from just about anywhere with cellular service. With the Viking Monitor App, this tool allows you to monitor and label multiple operators by site and location for quick reference. Provides error notifications, operator status, settings and diagnostic information.

Part# VA-MONITOR

Q-7 & ECU Operators require (1) Antenna Extension Cable (part# VA-RPSMA)



VIKING AC SURGE PRO Adds another layer of protection to the high voltage power supply of your gate operator. Connecting the AC Surge Pro in parallel to the EMI Board, provides a dual layer of protection from surges up to 20,000 Volts / 10,000 Amps. **Part# VA-SURGEPROAC**



VIKING SOLAR KIT The components included in this package are intended to provide sufficient power for general applications.

Part# VA-SOCHP

This Kit includes the following components:

- (2) **12V 40W Solar Panels** Part# VA-S040W **(wired in series = 24V 80W)**
- (2) **12V 35Ah batteries** Part# DUBA35 **(wired in series = 24V 35Ah)**
- (1) **Solar Charger** Part# SOCHR10
- (1) **Solar Power Harness** Part# SOHAR

⚠ NOTE: The number of cycles achieved from this kit are dependent upon the following and may require increased panel and battery capacities:

- Power consumption of all accessories being used
- Average solar radiation of geographic location

OUR CONTINUOUS COMMITMENT TO EXCELLENCE

Viking Access Systems is continuously working hard to identify and design products that will appeal to the industry and its needs. As technology continues to advance, we have developed a completely efficient and intelligent line of gate operators to meet the changing demands. These machines offer: full UL325 and UL991 compliance, soft-start and soft-stop, intelligent obstruction sensors, continuous operation (100% duty cycle) and extreme power efficiency. Innovative features include: adaptive and self-learning algorithms, redundancy design in both hardware and software to ensure operation and functionality, protection from lightning, short circuit and power surges, and our exclusive helical gearing offering the highest efficiency rating in the industry. Our entire product line is continually modified and improved based on the latest technology and our customer's valuable feedback. The results are products that offer accuracy, efficiency, reliability and performance, all in sleek, high-tech designs.

We pledge to continue establishing ourselves as the leader in high quality, innovative gate operators by developing "Next Level" technology. We are committed to providing safety and convenience with innovative solutions for every security gate need.



STANDARD FEATURES AND OPERATOR SPECIFICATIONS

- ETL Listed; UL325 and UL991
- Fire Authority compliant
- Manual Release Mechanism
- Elegant design, appealing to any architectural project
- Powder coated steel chassis
- Opening up to 110°
- 100% duty cycle
- Built-in power-outage management options
- Up to 250 continuous cycles of operation on backup battery
- Intelligent speed control with smooth start and stop, self-adjust system
- Intelligent obstruction detection with adjustable sensitivity
- Adjustable delay for overlapping dual gates
- Hold Open Timer to automatically close the gate
- Built-in protection against lightning strikes or similar electrical surges
- Inherent overload protection; redundancy design using multiple types of protection
- Modular connectors for easy access control and accessory installation
- Regulated power supply for your external accessories
- LED indicators display gate and operator status for easy troubleshooting
- On-Board LCD Display provides diagnostics, operator status, settings and real-time volt and amp readings
- Built-in motor heater for cold weather applications
- Equipped for 115/230 VAC, 24 VAC/VDC and Solar power supplies

INSTALLATION DATE: _____

COMPANY / INSTALLER: _____

CONTACT: _____

SERIAL NUMBER(S): _____

ALL INSTALLATION, MAINTENANCE AND REPAIR WORK MUST BE DOCUMENTED AND MADE AVAILABLE TO THE USER.



VIKING ACCESS SYSTEMS

631 Wald Irvine, CA 92618

Phone 800.908.0884

Fax 949.753.1640

www.vikingaccess.com