

powermaster

MG

Door Operator for Sectional Doors with High Lift or Vertical Lift and Rolling Service Doors & Grilles.

MG

STANDARD FEATURES

- HIGH STARTING TORQUE MOTOR WITH FULL OVERLOAD PROTECTION
- ON BOARD OPEN/CLOSE/STOP BUTTONS FOR SERVICE AND ADJUSTMENTS
- SOLID STATE CIRCUITRY WITH FEEDBACK LEDs
- FIELD ADJUSTABLE BUILT-IN FUNCTIONS
- AUTO-DETECT MONITORED PHOTO BEAM FOR SIMPLIFIED INSTALLATION
- FLOOR LEVEL DISCONNECT W/CHAIN HOIST INTERLOCK FOR MANUAL OPERATION



VARIABLE SPEED MODIFICATION AVAILABLE



Complete selection of control stations & accessories are available.

All door operators are required to have a monitored safety system, such as monitored photo eyes and/ or monitored 2 or 4 wire obstruction sensing edge. In addition, an ancillary device may be used. The primary device must be a constantly monitored, anti entrapment/safety device.



Facebook.com/PowerMasterOperators

www.PowerMasterNY.com

SERVICING THE INDUSTRY SINCE 1969

SPECIFICATIONS & FEATURES

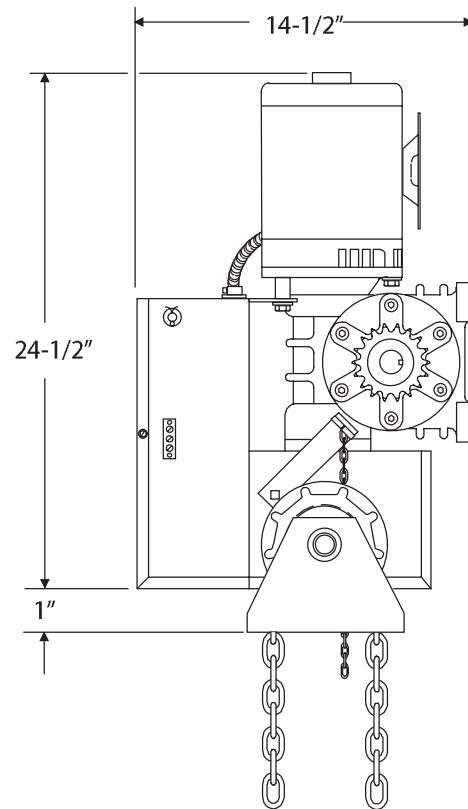
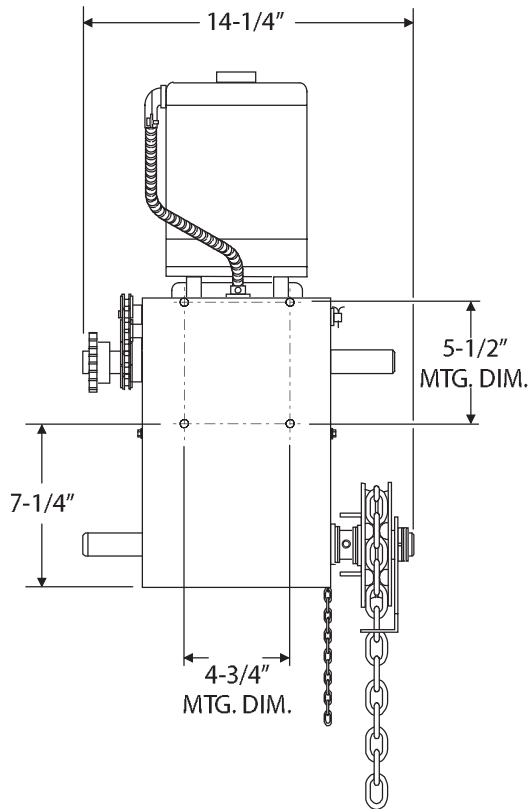

AVAILABLE HORSE POWER: 1/2 HP - 7.5 HP

POWER OPTIONS: 115/230 VOLTS, 1 PHASE; OR 208/230/460 VOLTS, 3 PHASE

SELECTABLE OPERATING MODES B2, C2, D1, E2, T, TS

FIELD ADJUSTABLE BUILT IN FUNCTIONS INCLUDING: TIMER TO CLOSE, MID-STOP, DELAY ON REVERSE, LOCK BAR SENSING, MAXIMUM RUN TIME, ETC.

ADJUSTABLE TORQUE LIMITING CLUTCH AVAILABLE

HEAVY DUTY #50 ROLLER CHAIN AND DRIVE SPROCKET INCLUDED

MECHANICALLY SELF LOCKING GEAR REDUCER (OIL BATH TYPE)

BAKED ON, BLACK POWDER COAT FINISH

SHIPPING WEIGHT: 1/2 HP - 1 HP: 100 LBS
 1-1/2 HP - 2 HP: 141 LBS
 3 HP: 254 LBS
 5 HP: 600 LBS
 7 HP: 700 LBS

CAUTION

A moving door can cause serious injury or death! Carefully read and follow all safety instructions, precautions, and guidelines when installing and using this product. Motorized doors are for vehicles only. Pedestrians must use a separate entrance. **NO ONE SHOULD CROSS THE PATH OF A MOVING DOOR!** Proper reversing devices must be installed to avoid all hazards and entrapment. Eliminate all hazards and entrapment areas. Warning signs must be permanently installed and visible to traffic and pedestrians. Never allow children to operate or play with controls. Follow UL 325 and ASTM F220-02 standards. Do not install this product unless all hazards and entrapment points are protected.

